

**Bioinformatics using the eBioKit Platform – Commission
for Biotechnology & Genetic Engineering, National
Center for Research**

Mark Wamalwa
BecA-ILRI Hub, Nairobi, Kenya
<http://hub.africabiosciences.org/>
m.wamalwa@cgiar.org



1st – 6th December 2014
biosciences
eastern and central **africa**

Plan for the week

Day 1

Day 2

Day 3

Day 4

Day 5

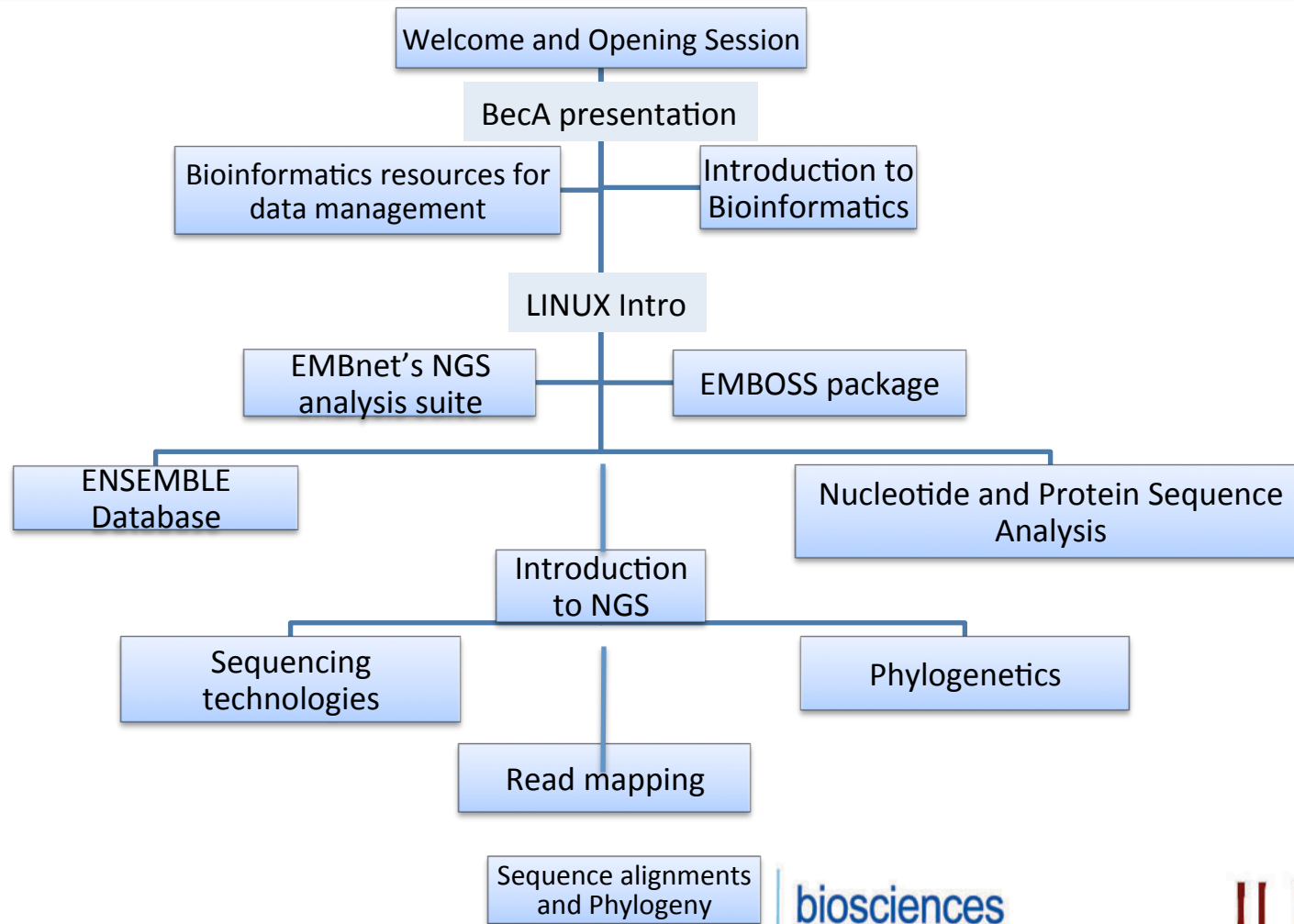

Phylogeny

Outgroup
Species A
Species B
Species C

AAGCTTCATAGGAGCAACCATTCCTAATAATAAGCCTCATAAAGCC
AAGCTTCACCGGCGCAGTTATCCTCATAATATGCCTCATAATGCC
GTGCTTCACCGACGCAGTTGTCCTCATAATGTGCCTCACTATGCC
GTGCTTCACCGACGCAGTTGCCCTCATGATGAGCCTCACTATGCA

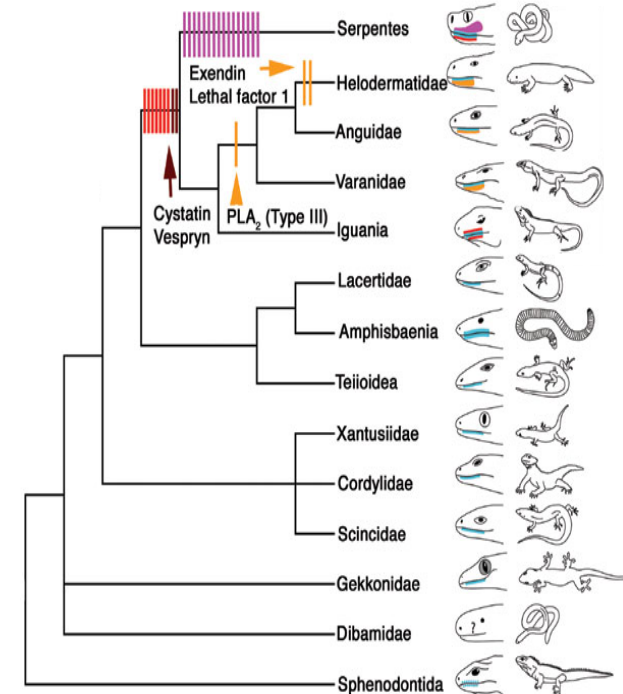
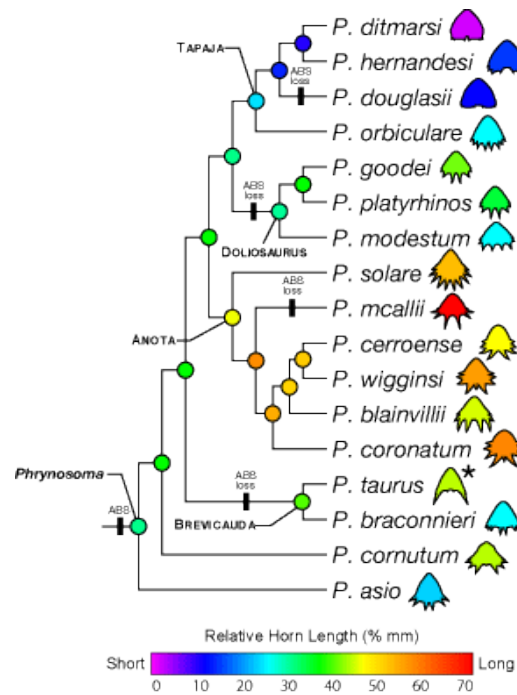
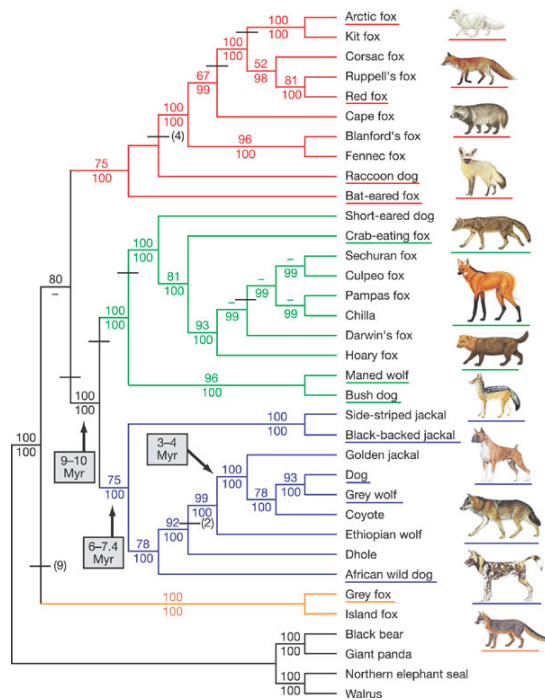

What is phylogenetics?

- study of evolutionary relatedness among groups of organisms, achieved by:
 - Comparison of molecular data
 - Comparison of morphological data

Objectives of phylogenetics

- Reconstruct the correct genealogical ties among biological entities i.e. to reconstruct the evolutionary history of organisms
- Estimate the time of divergence between biological entities
- Chronicle the sequence of events along evolutionary lineages
- To depict the phylogenies, the historical events = evolution of species / genes in tree graphs

Some history...



An abstract of an Essay
on the
Origin
of
Species and Varieties
through natural selection
by
Charles Darwin M.A.
Fellow of the Royal, Geological & Linn. Soc^s.

London
1859

Charles Darwin to Thomas Huxley (1881)



“The time will come I believe, though I shall not live to see it, when we shall have fairly true genealogical [phylogenetic] trees of each great kingdom of nature.”



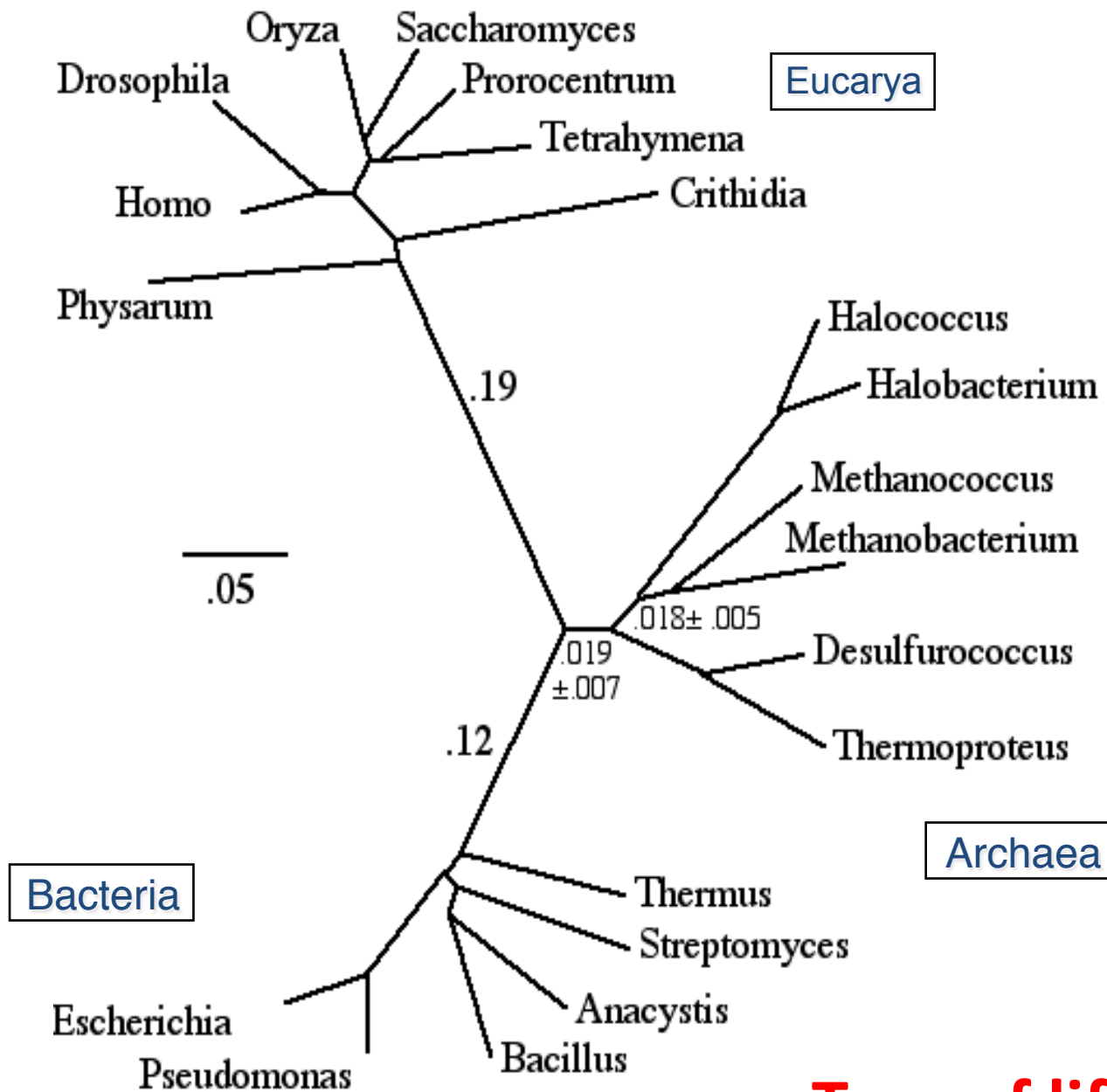

Universal phylogeny

deduced from comparison of SSU and LSU rRNA sequences (2508 homologous sites) using Kimura's 2-parameter distance and the NJ method.

The absence of root in this tree is expressed using a circular design.

Tree of life

Phylogeny

What is a phylogeny?

Branching diagram showing relationships between species (or higher taxa) based on their shared common ancestors

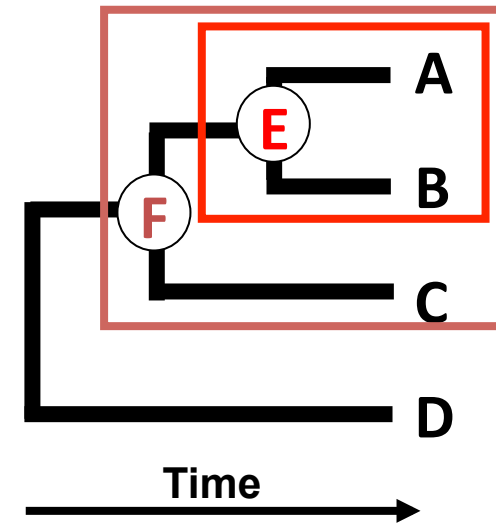
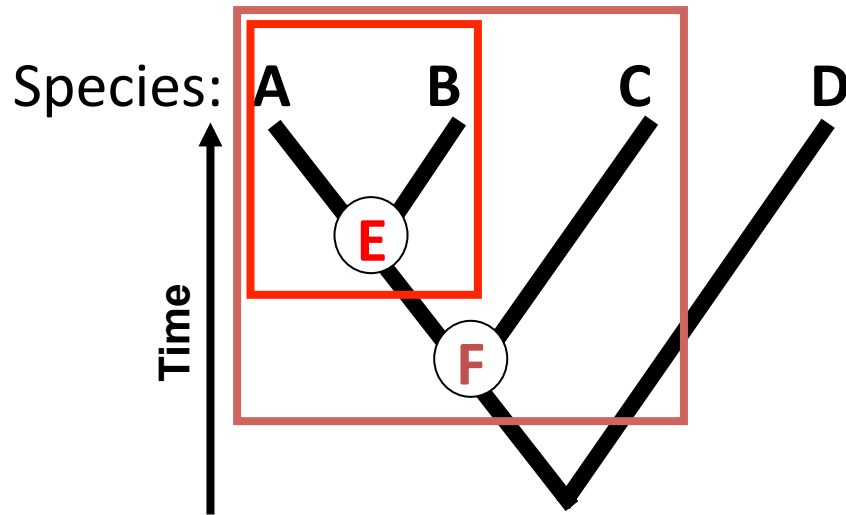

A and B are most closely related because they share a common ancestor (call the ancestor “E”) that C and D do not share

A+B+C are more closely related to each other than to D because they share a common ancestor (“F”) that D does not share

Evolutionary Forces in modifying genetic information

Evolutionary processes include:

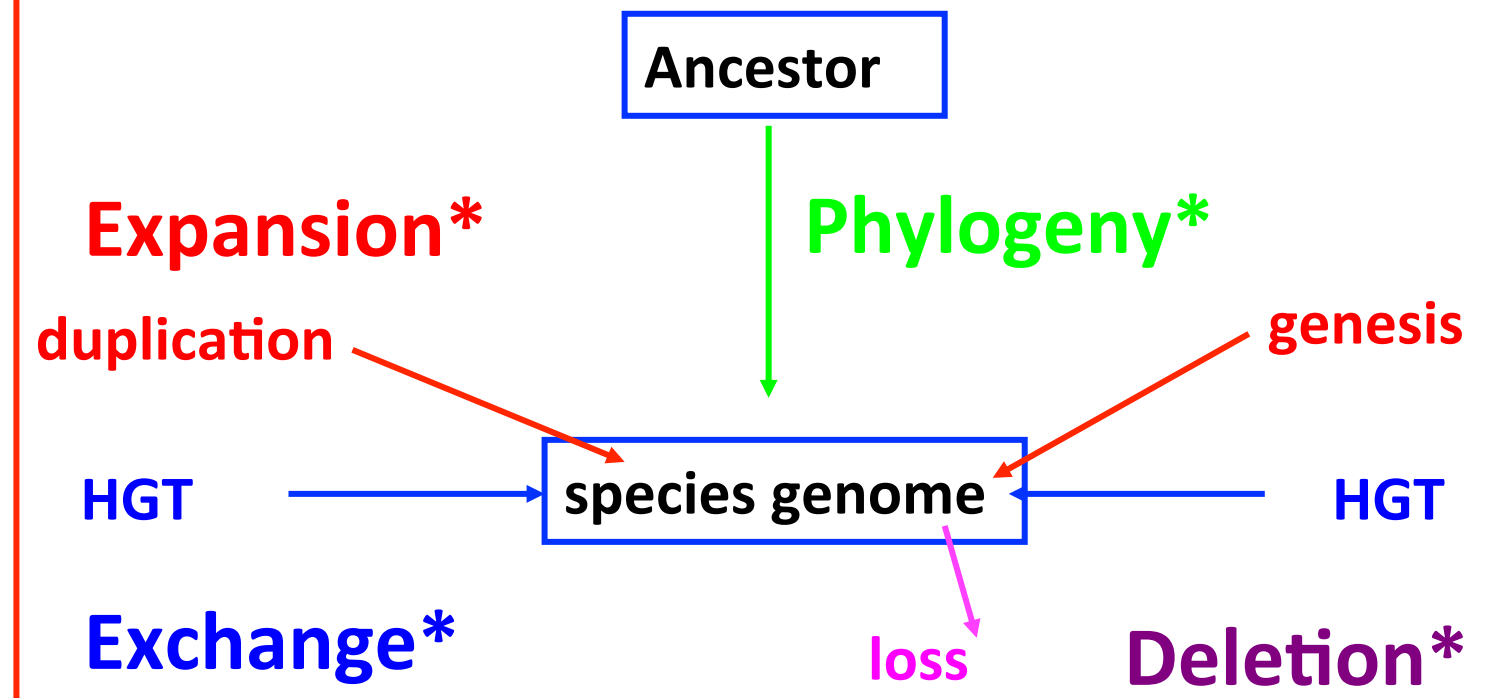

Tree of life

Why is phylogeny important?

Understanding and classifying the diversity of life on Earth

Testing evolutionary hypotheses:

- trait evolution
- coevolution
- mode and pattern of speciation
- correlated trait evolution
- biogeography
- geographic origins
- age of different taxa
- nature of molecular evolution
- disease epidemiology

...and many more applications!

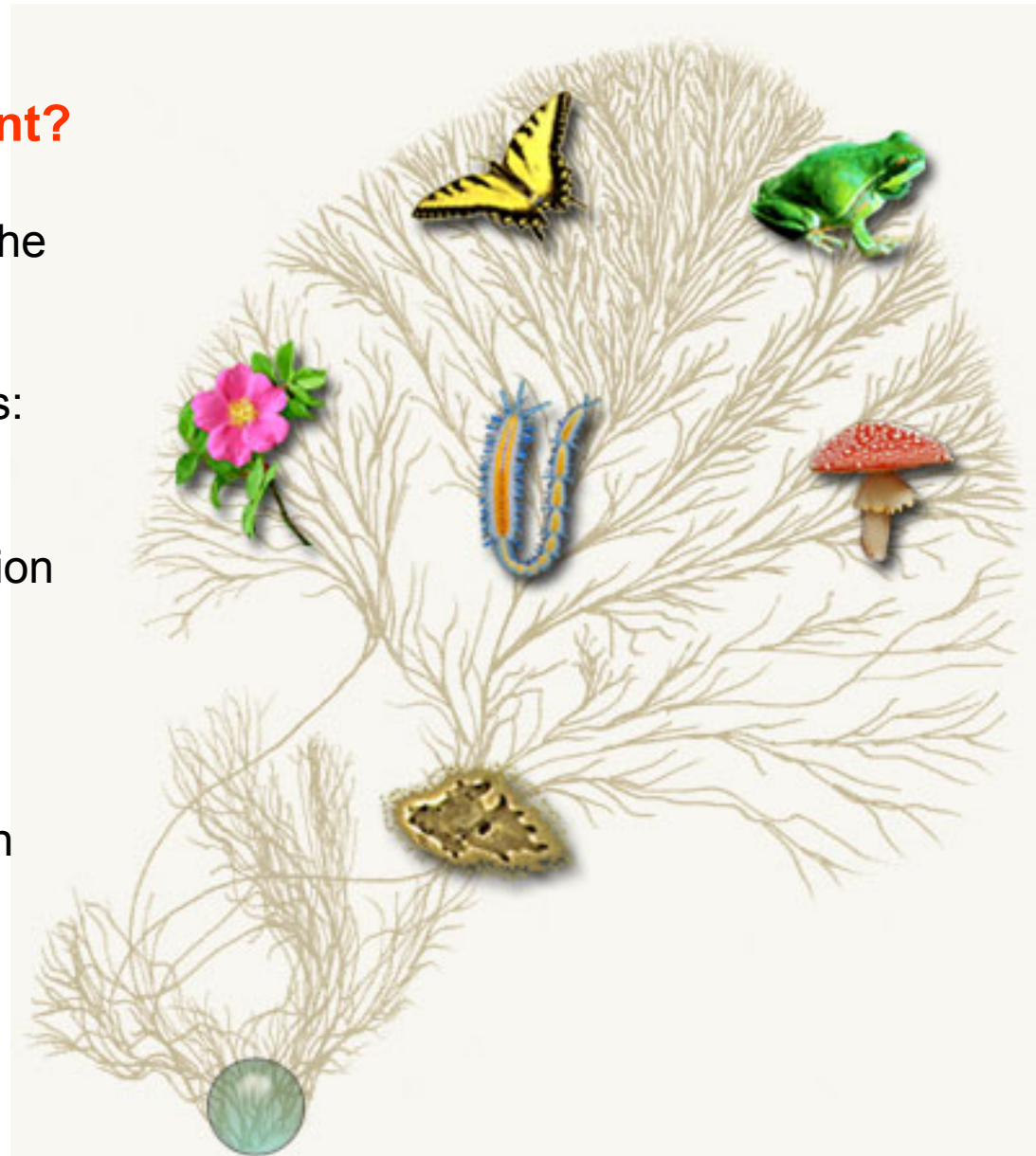

Tree Terminologies

- ✓ Internal branch : between 2 nodes.
- ✓ External branch : between a node and a leaf
- ✓ Horizontal branch length is proportional to evolutionary distances between sequences and their ancestors (unit = substitution / site).
- ✓ Tree Topology = shape of tree = branching order between nodes

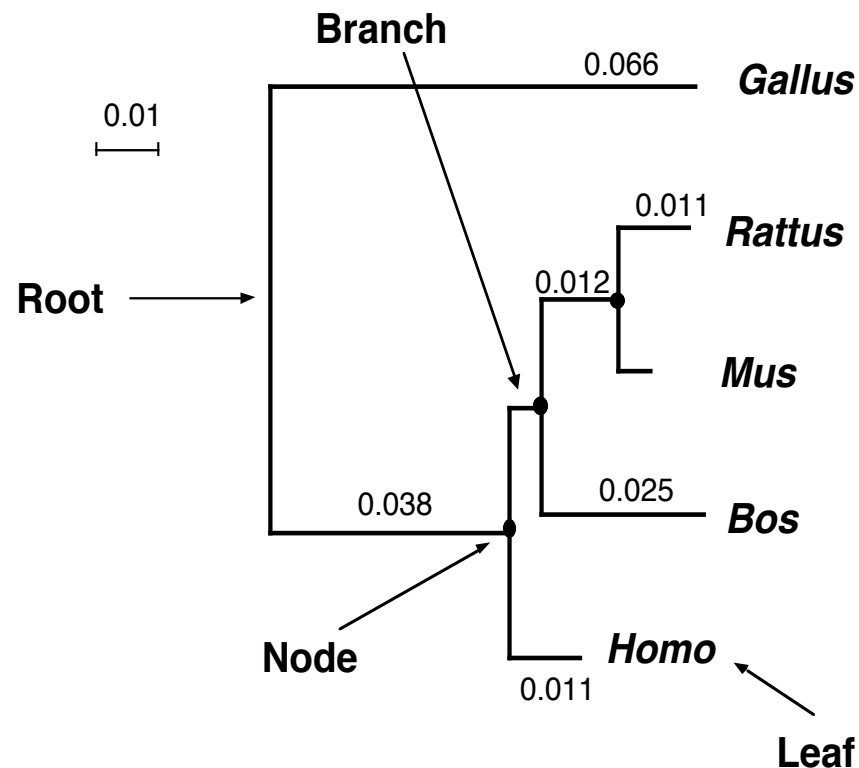

Phylogeny

Terminal nodes = contemporary taxa

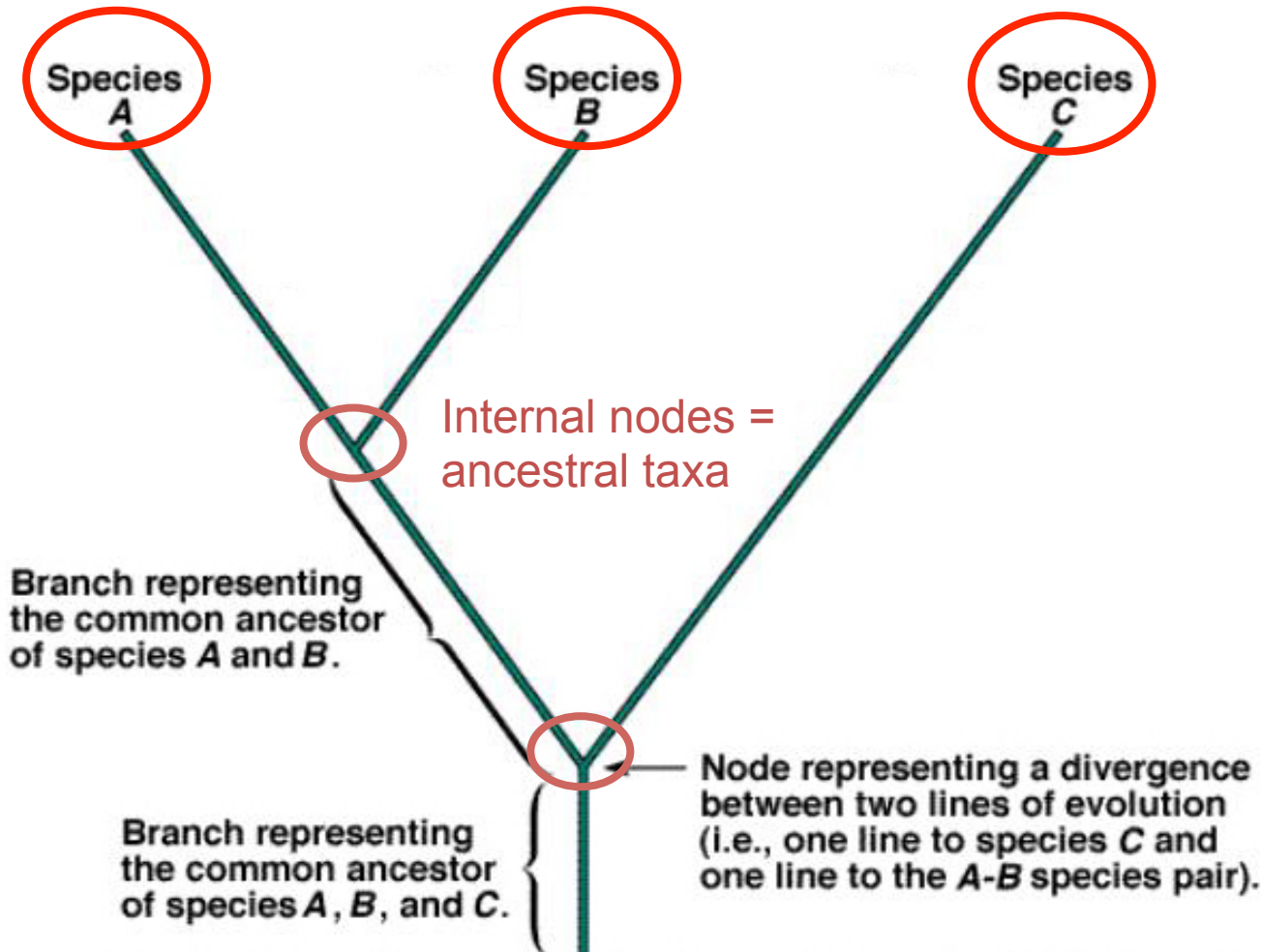

Phylogeny and classification

Hierarchy

All taxonomic classifications are hierarchical – how does phylogeny differ?

NB: taxa are nested on the basis of shared common ancestors

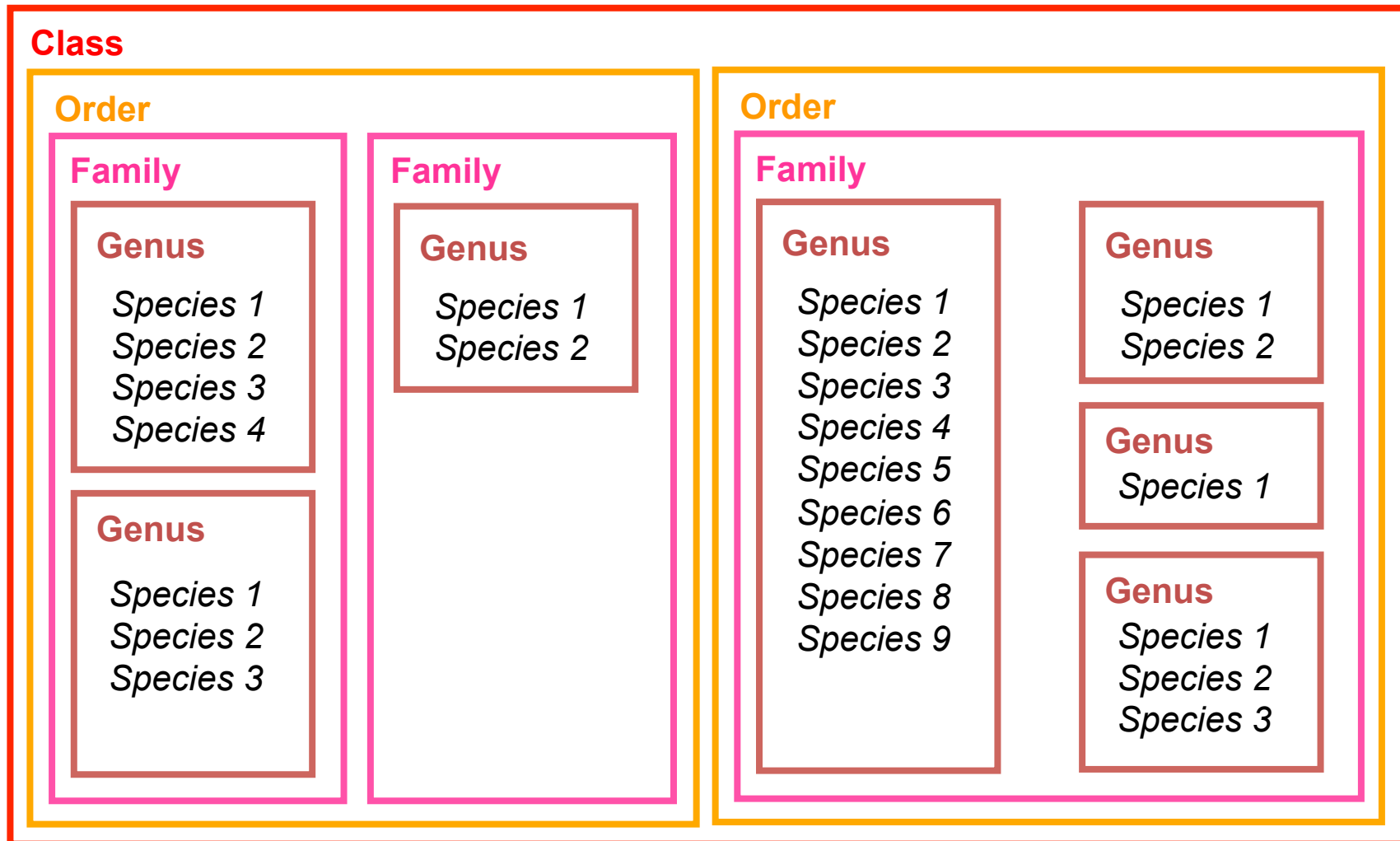

Phylogeny and classification

Hierarchy

Phylogenetic (cladistic) classification reflects evolutionary history

The only objective form of classification – organisms share a true evolutionary history regardless of our arbitrary decisions of how to classify them

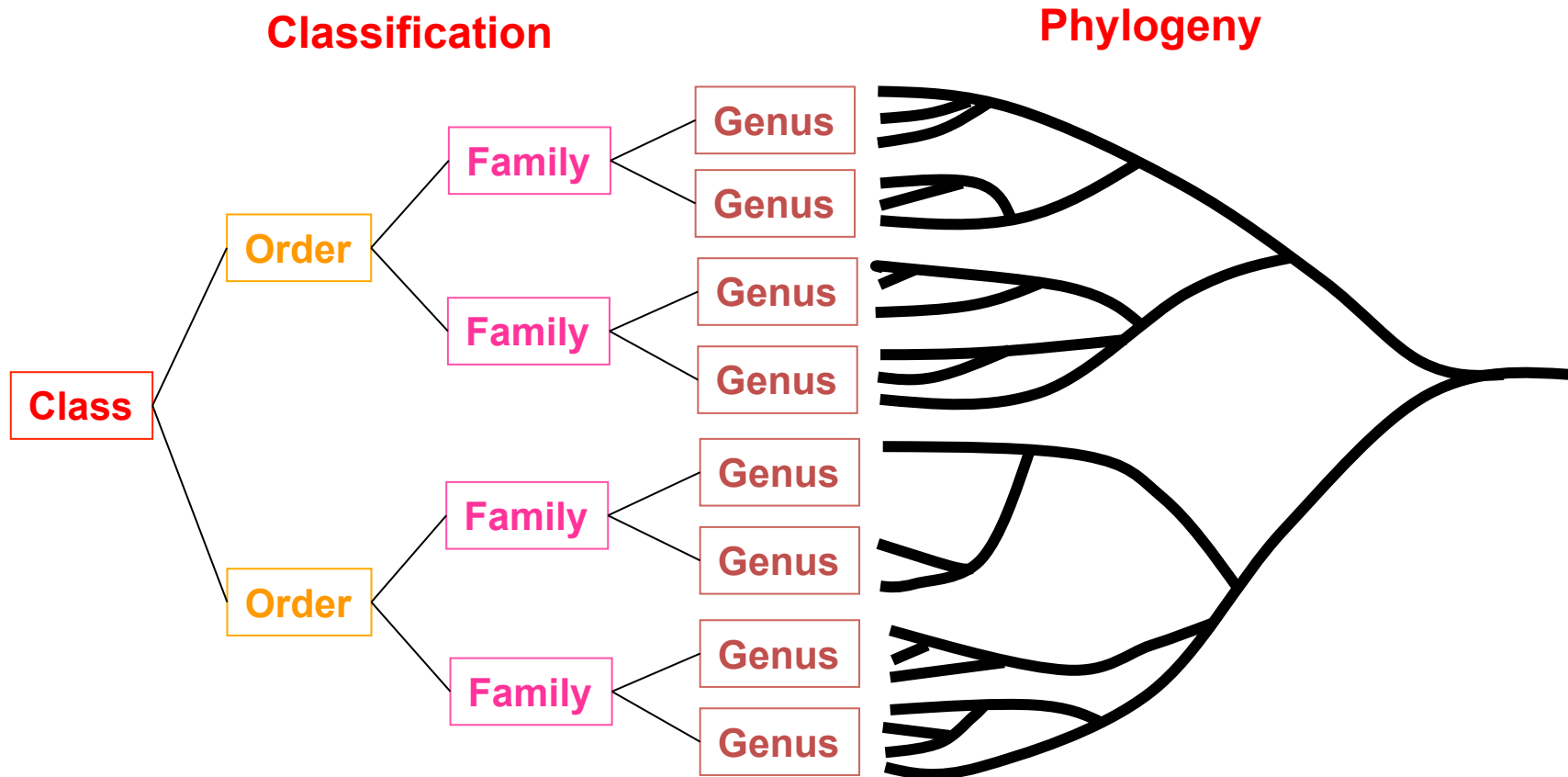

Phylogeny and classification

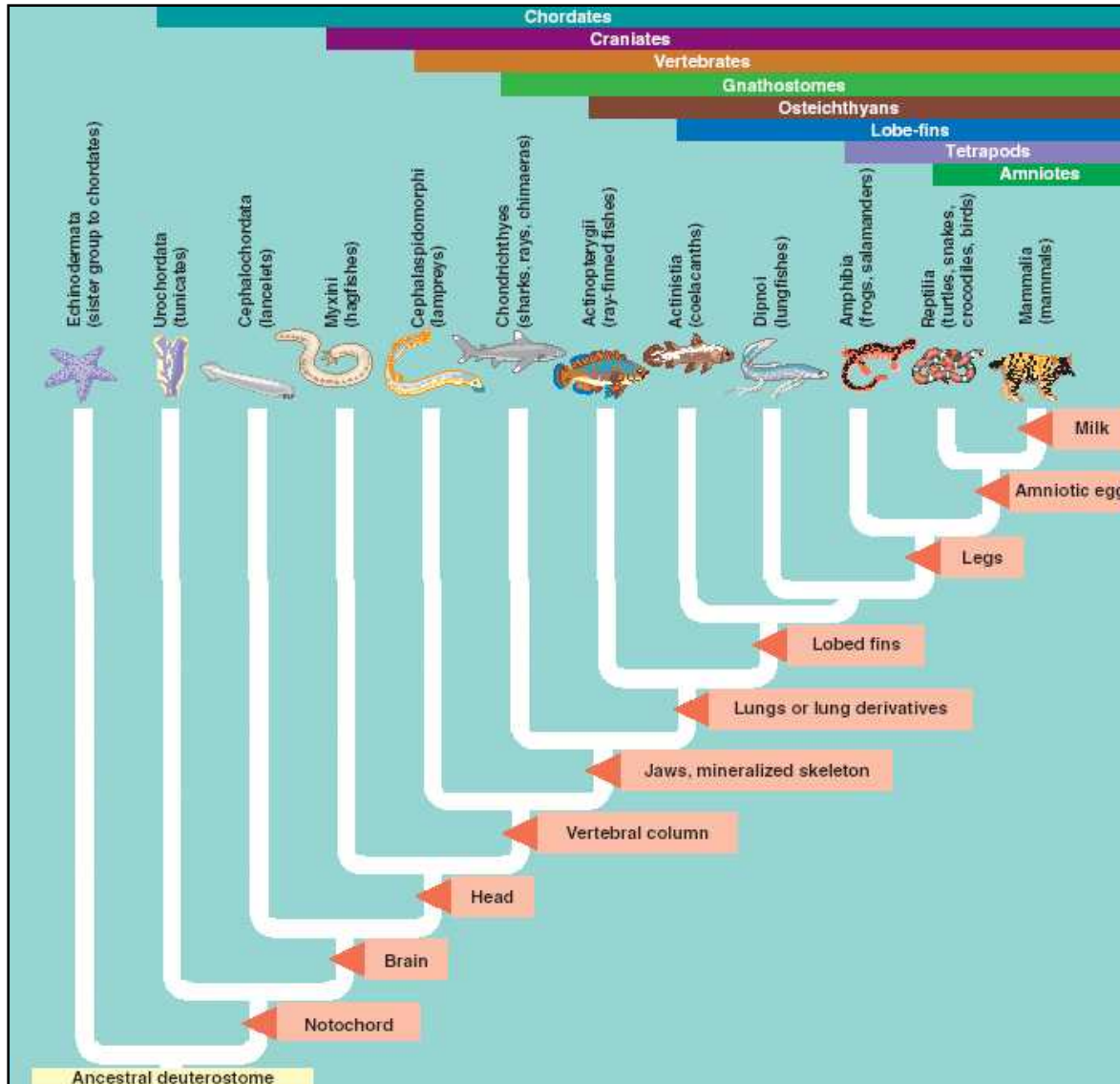

Classification

Note that taxa are nested on the basis of shared common ancestors

e.g., All tetrapods share a common ancestor with legs, but other chordates outside of Tetrapoda do not share this common ancestor

The traits mapped onto the phylogeny are **synapomorphies** – we will return to them later

Phylogeny and classification

Monophyletic group

Includes an ancestor
all of its descendants

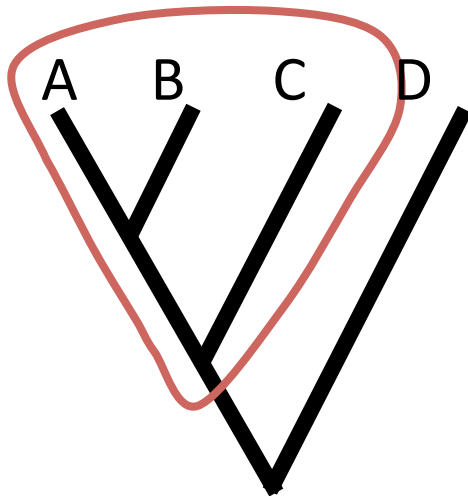

How could this happen?

Paraphyletic group

Includes ancestor and
some, but not all of its
descendants

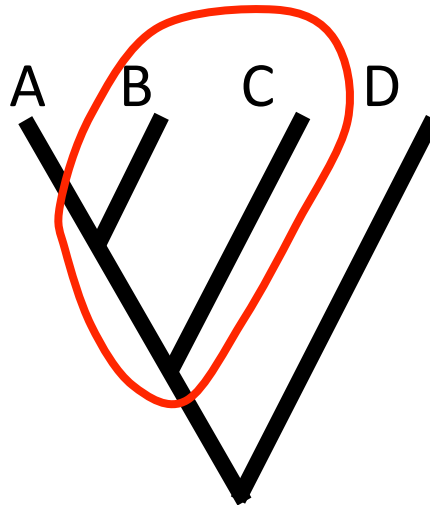

Taxon A is highly derived
and looks very different
from B, C, and ancestor

Polyphyletic group

Includes two convergent
descendants but not their
common ancestor

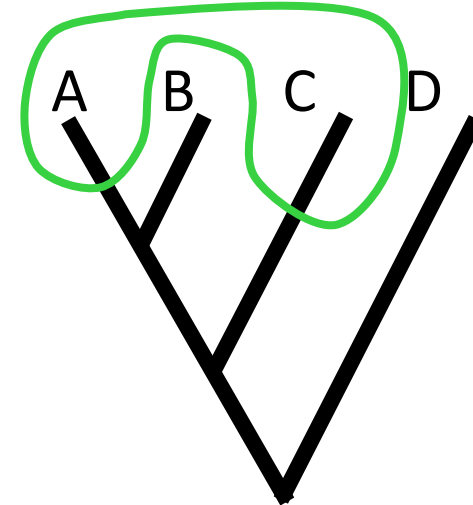

Taxon A and C share
similar traits through
convergent evolution

Only monophyletic groups (**clades**) are recognized in cladistic classification

Phylogeny and classification

Monophyly

Each of the colored lineages in this echinoderm phylogeny is a good monophyletic group

Asterozoa

Ophiurozoa

Echinozoa

Holothurozoa

Crinozoa

Each group shares a common ancestor that is not shared by any members of another group

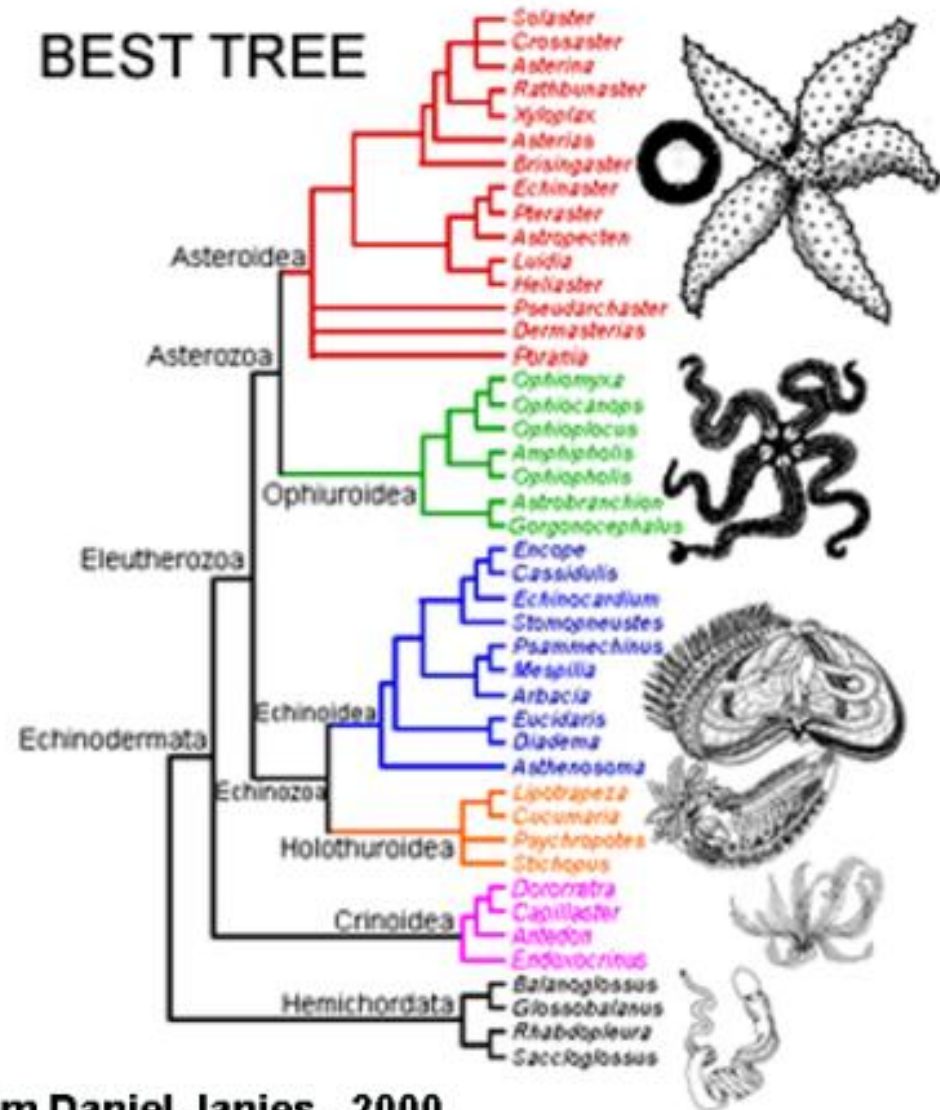

From Daniel Janies. 2000.

Paraphyletic groups

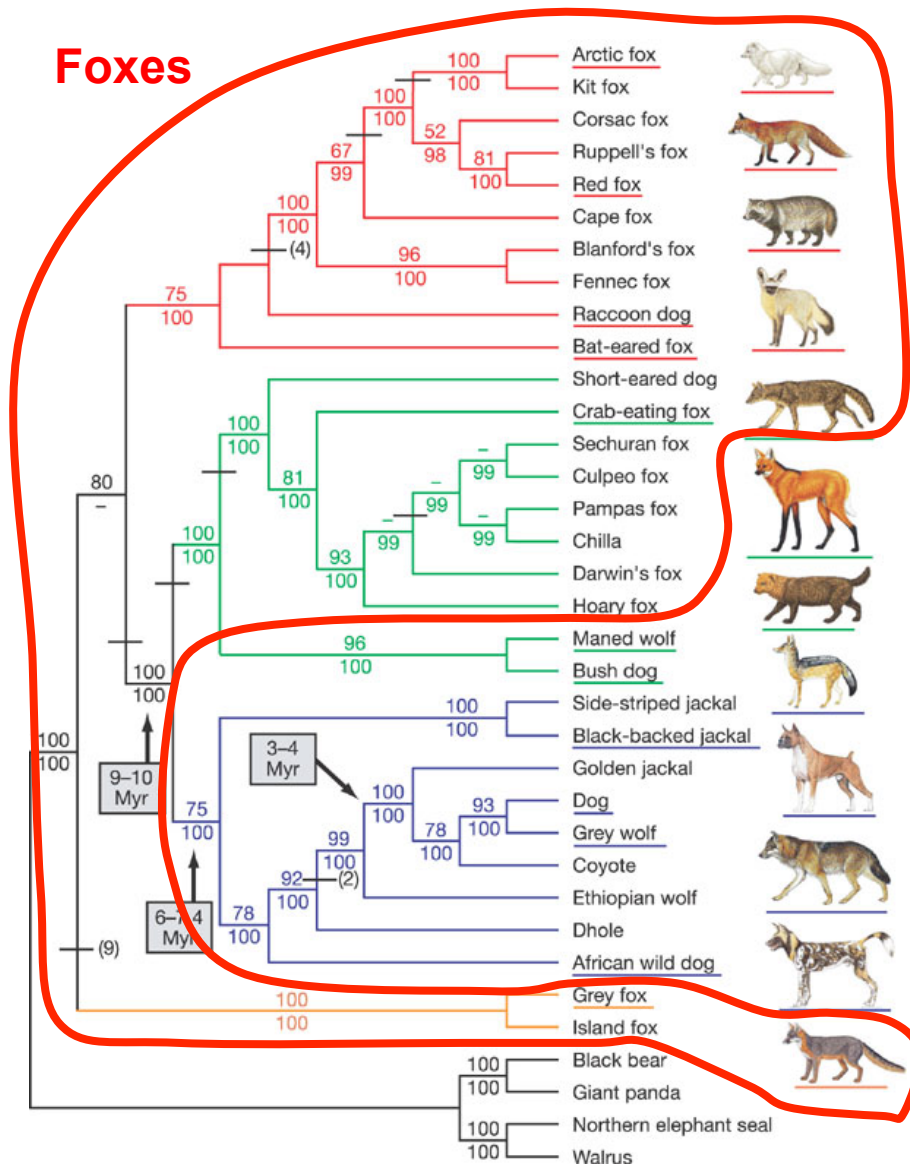

Paraphyly

“Foxes” are **paraphyletic** with respect to dogs, wolves, jackals, coyotes, etc.

This is a trivial example because “fox” and “dog” are not formal taxonomic units, but it does show that a dog or a wolf is just a derived fox in the phylogenetic sense

Paraphyletic groups

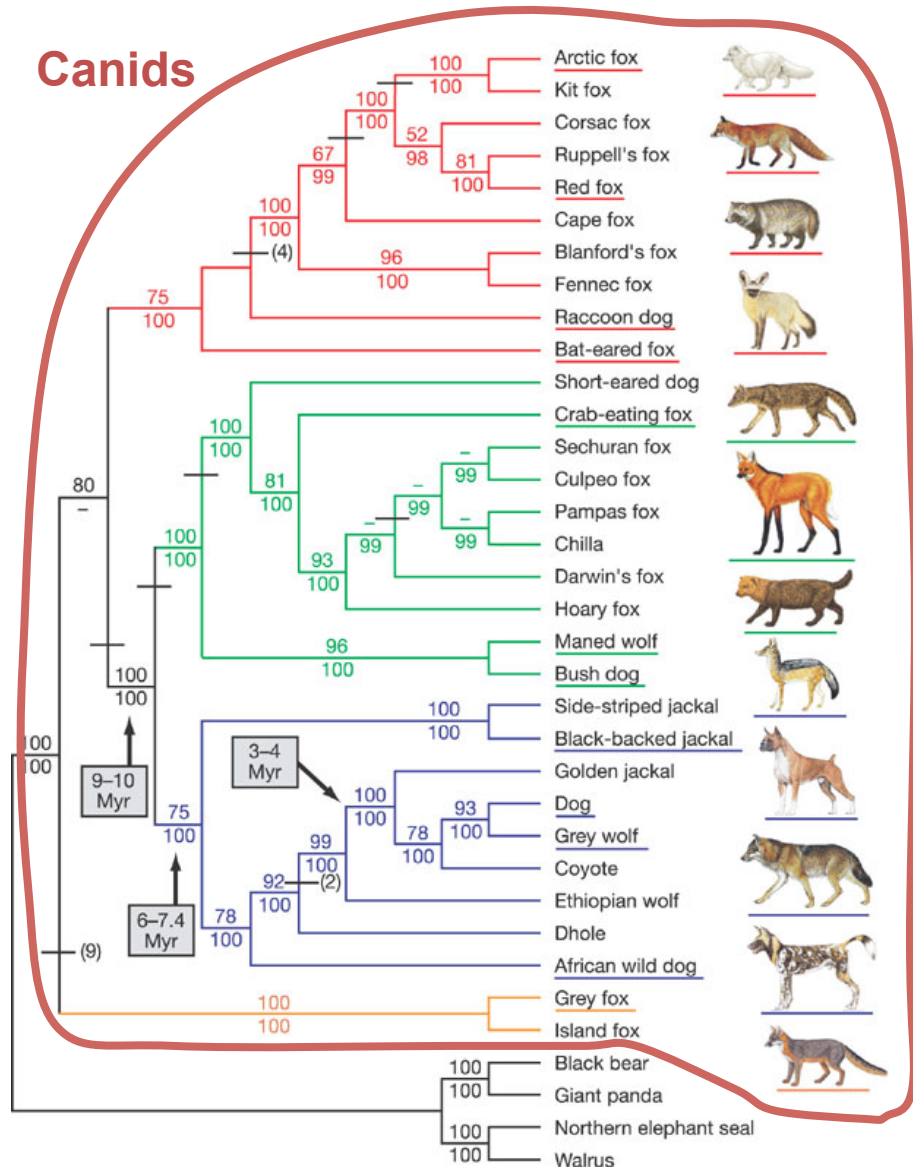

Monophyly

Note that canids are still a good **monophyletic** clade within Mammalia

Each of the colored lineages within canids is also a **monophyletic** clade

Paraphyletic groups

Lizards

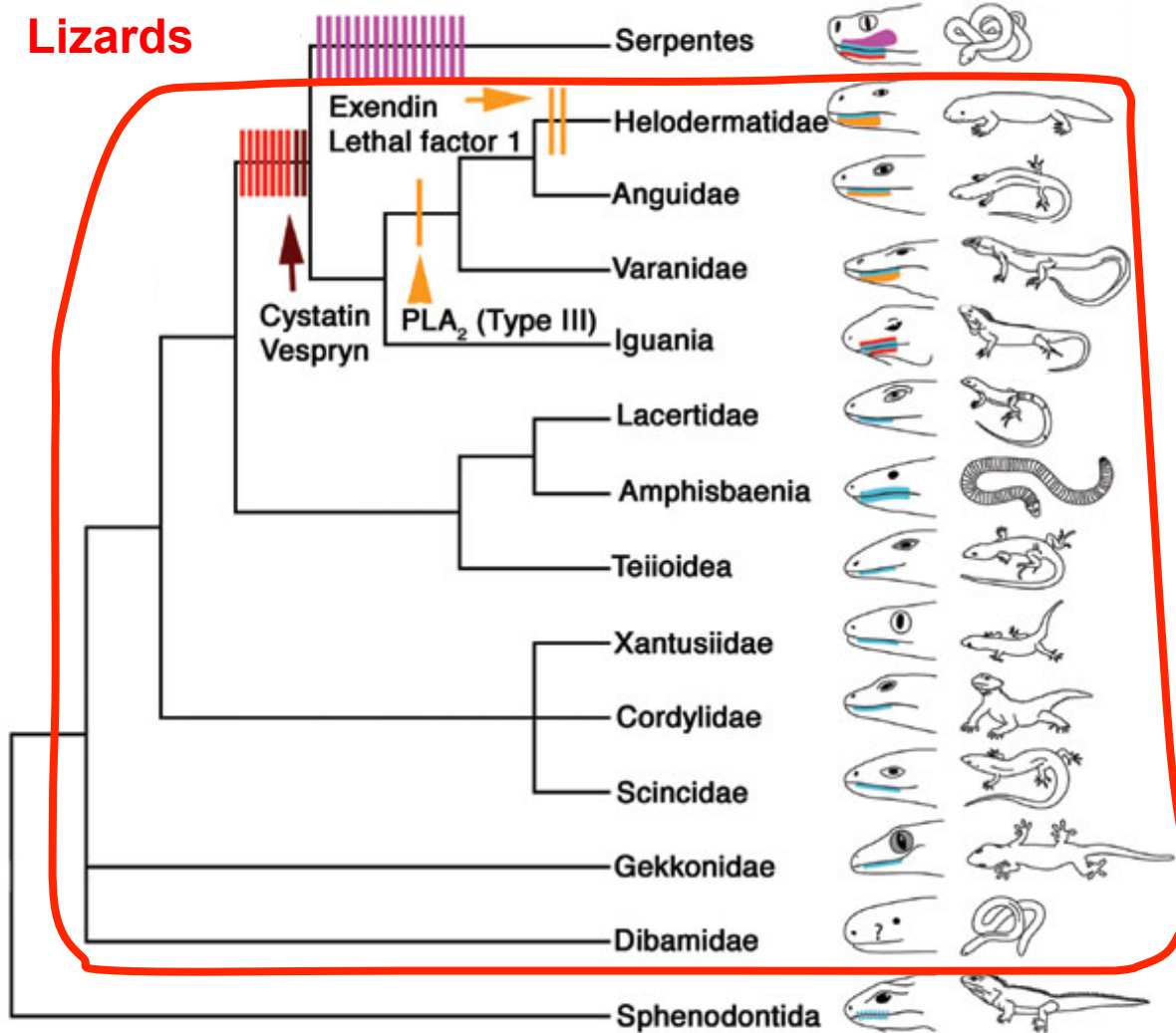

Paraphyly

“Lizards” (Sauria) are **paraphyletic** with respect to snakes (Serpentes)

Serpentes is a **monophyletic** clade within lizards

Squamata (lizards + snakes) is a **monophyletic** clade sister to sphenodontida

Snakes are just derived, limbless lizards

Paraphyletic groups

Reptilia

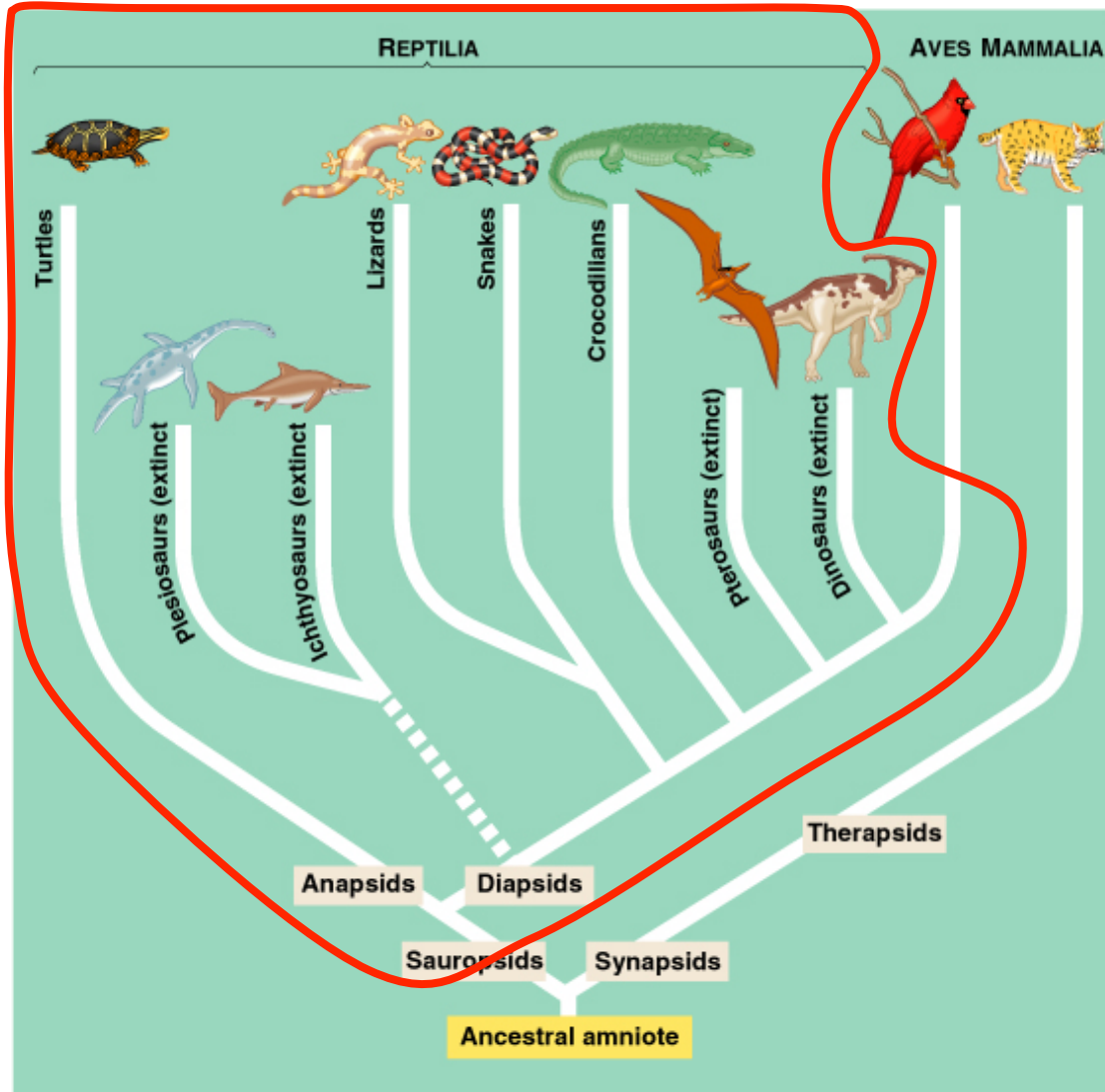

Paraphyly

Birds are more closely related to crocodillians than to other extant vertebrates

Archosauria = Birds + Crocs

We think of reptiles as turtles, lizards, snakes, and crocodiles

But Reptilia is a **paraphyletic** group unless it includes Aves

What does this mean?

It means that “reptiles” don’t exist!



No, it means that you’re one of us!

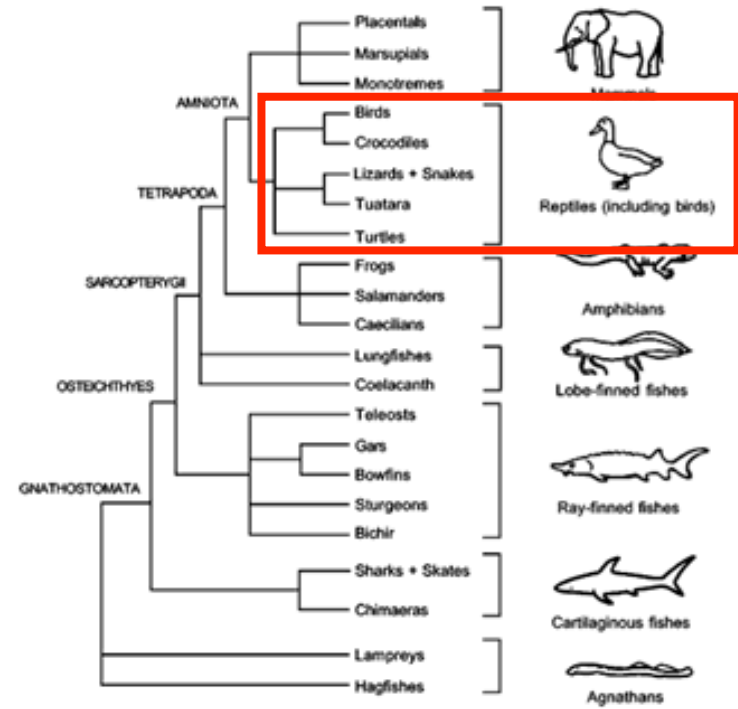
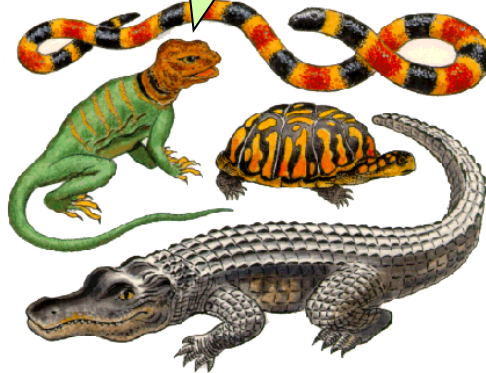

What it means is that “reptile” is only a valid clade if it *includes* birds

Birds are still birds, but Aves cannot be considered a “Class” equivalent to Class Reptilia because it is evolutionarily nested *within* Reptilia

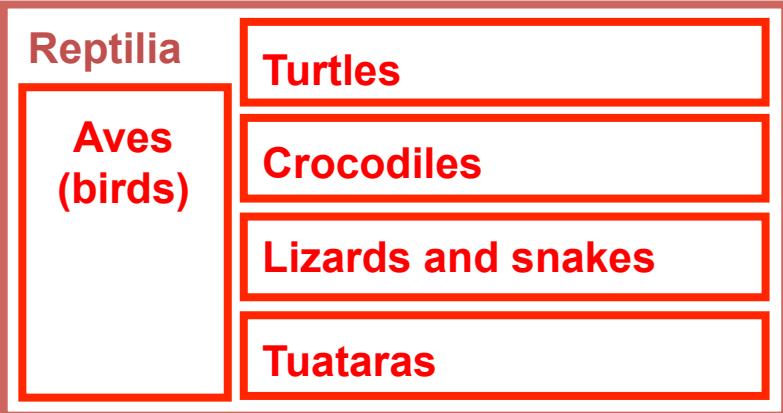

Testing evolutionary hypotheses

Mapping evolutionary transitions

Some horned lizards squirt blood from their eyes when attacked by canids

How many times has blood-squirting evolved?



Blood squirting? No Yes

P. modestum

P. platyrhinos

P. mcallii

P. solare

P. cornutum

P. coronatum

P. hernandesi

P. douglasi

Testing evolutionary hypotheses

Mapping evolutionary transitions

Some horned lizards squirt blood from their eyes when attacked by canids

How many times has blood-squirting evolved?

This phylogeny suggests a single evolutionary gain and a single loss of blood squirting



Blood squirting? ● No ● Yes

■ Blood-squirting
■ Loss of blood-squirting

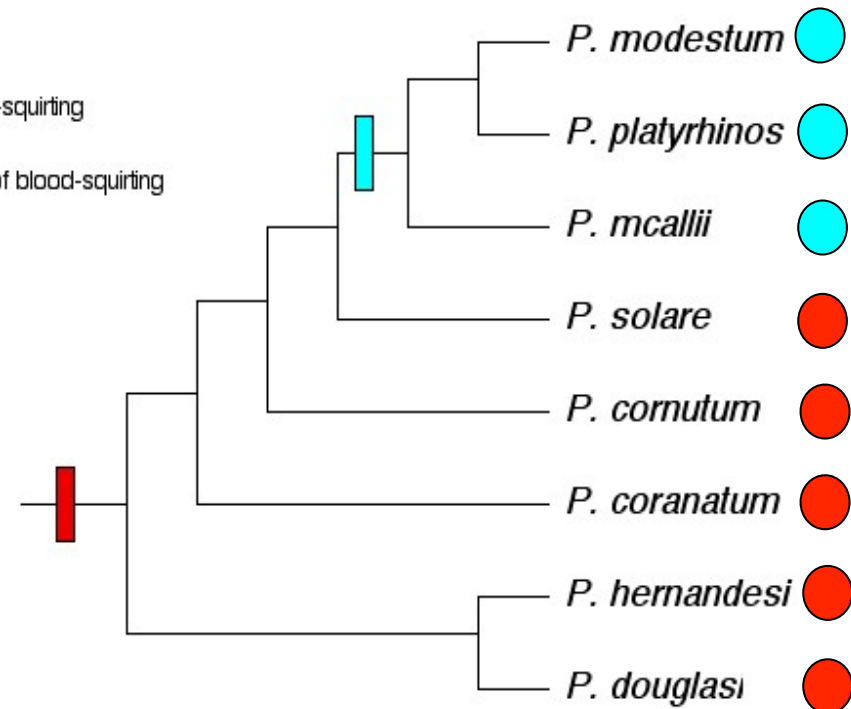

Testing evolutionary hypotheses

Mapping evolutionary transitions

But a new phylogeny using multiple characters suggests that blood squirting has been lost many times in the evolution of this group

Our interpretation of these evolutionary scenarios depends on phylogeny

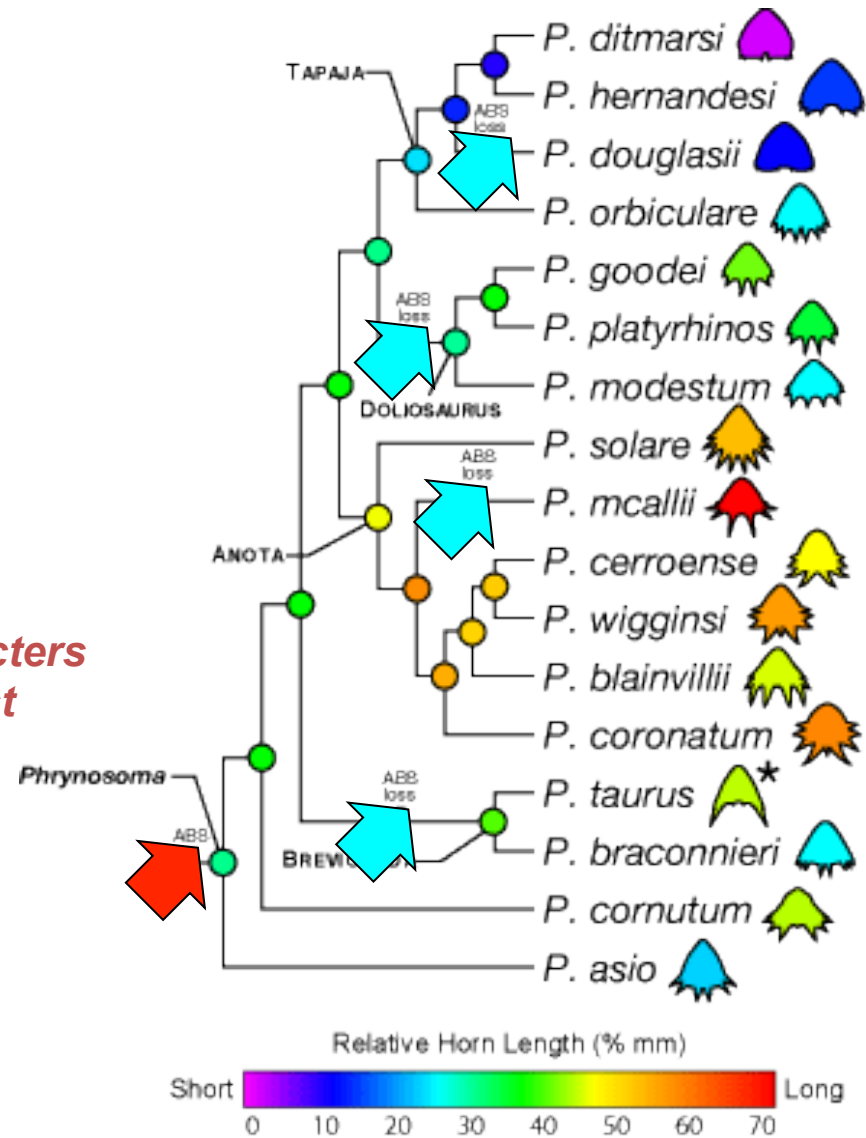

Testing evolutionary hypotheses

Reconstructing ancestral characters

This phylogeny also shows how we can use data from living species to infer character states in ancestral taxa

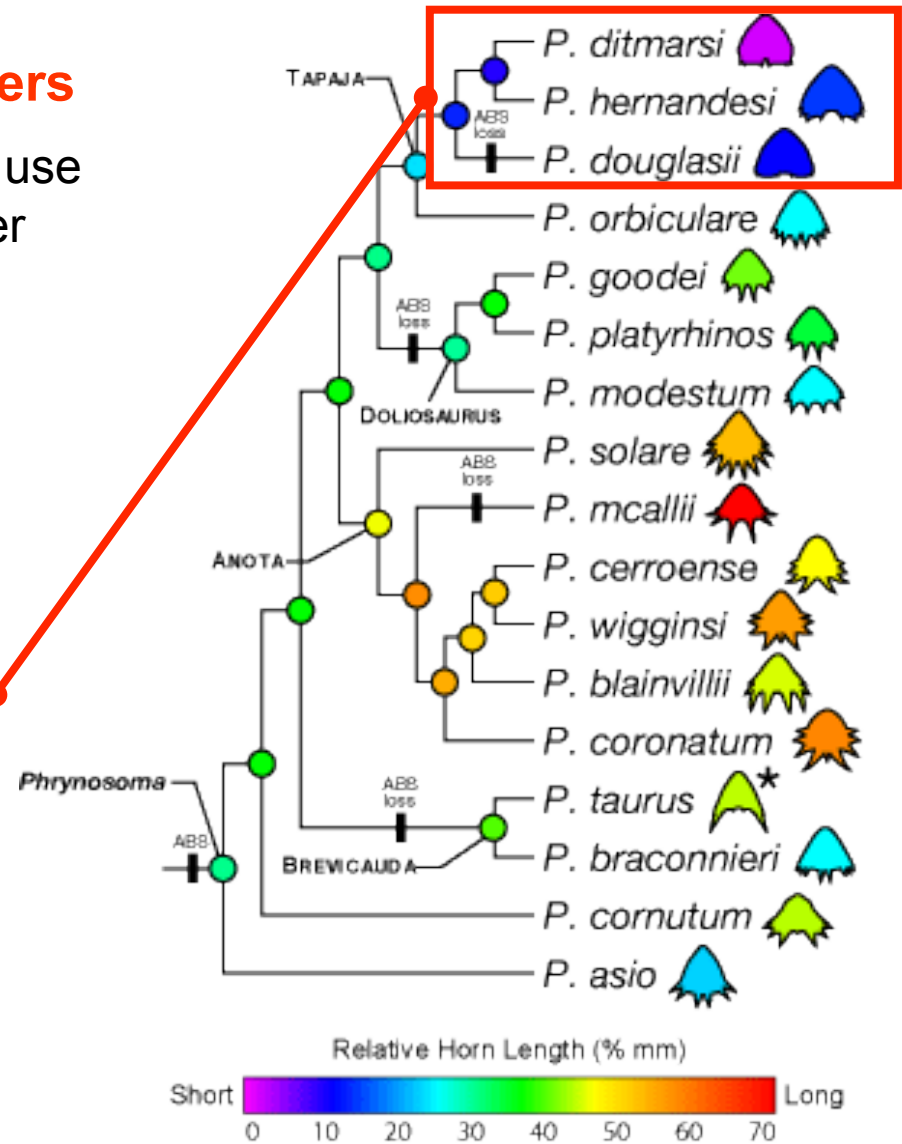
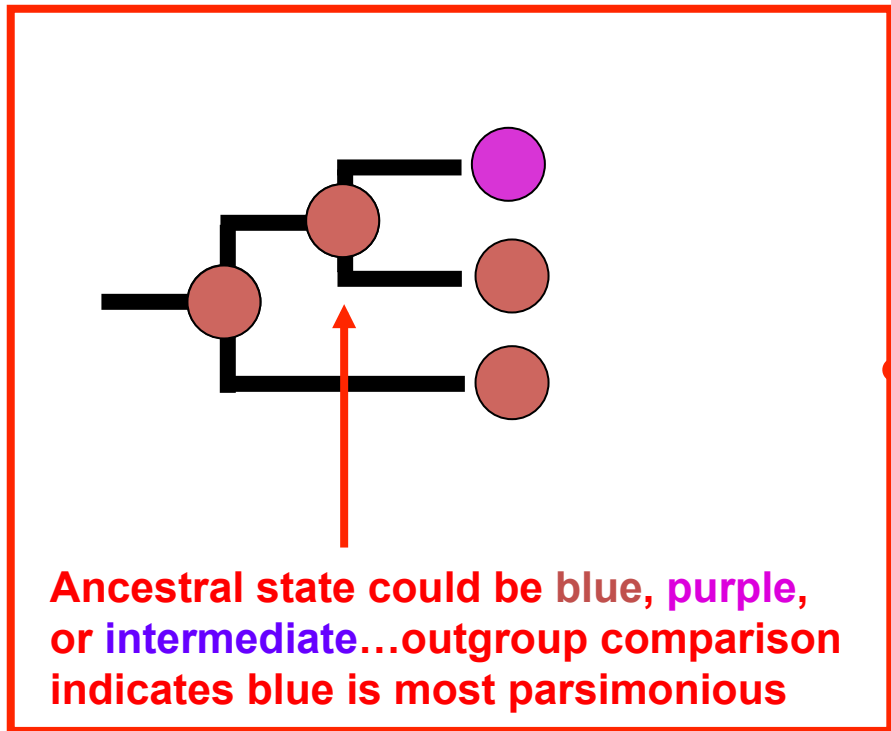

Testing evolutionary hypotheses

Mapping evolutionary transitions

How many times has venom evolved in squamate reptiles?

Once in the large “**venom clade**”

Groups within this clade then evolved different venom types

e.g., different proteins found in **Snakes** versus **Gila monsters**

Even non-venomous lizards in this clade (**Iguania**) share ancestral toxins

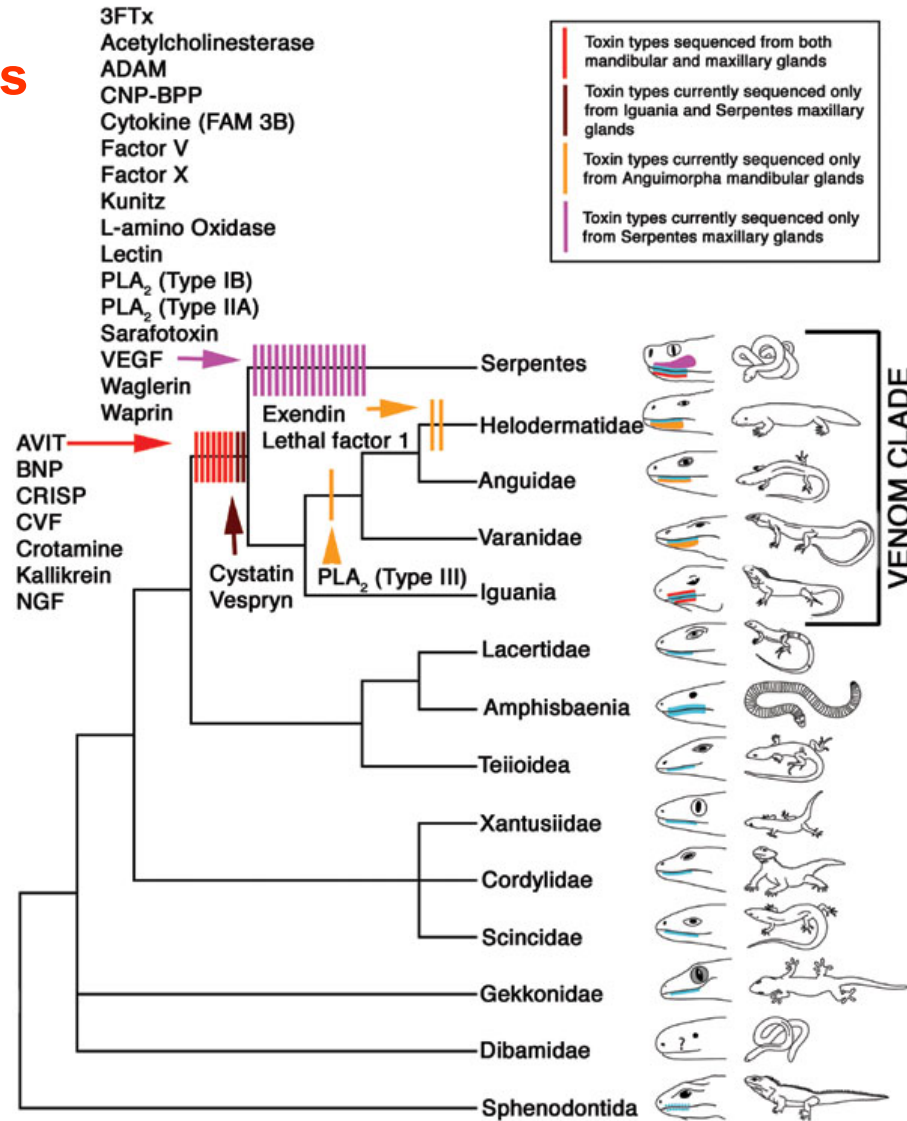

Fry et al. (2006) *Nature* 439: 584-588

Testing evolutionary hypotheses

Convergence and modes of speciation

What can this phylogeny tell us about homology/analogy and speciation?

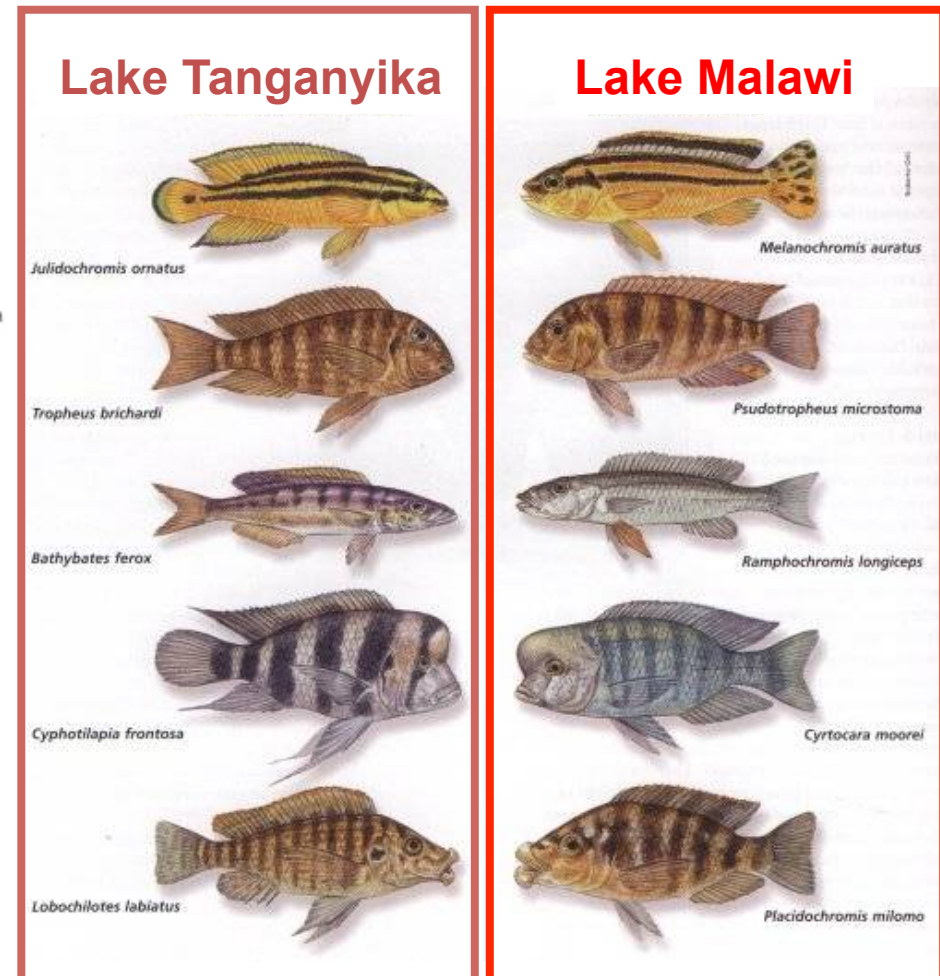
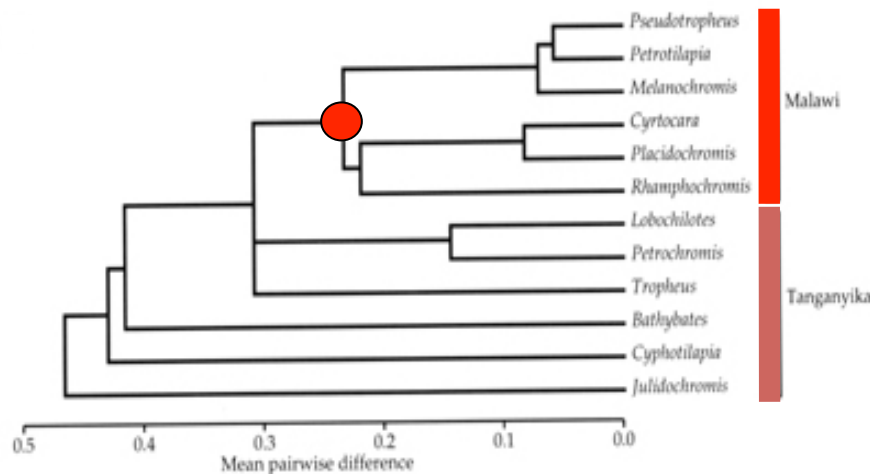

1. Similarities between each pair are the result of **convergence**
2. **Sympatric speciation** more likely than allopatric speciation

Testing evolutionary hypotheses

(c)

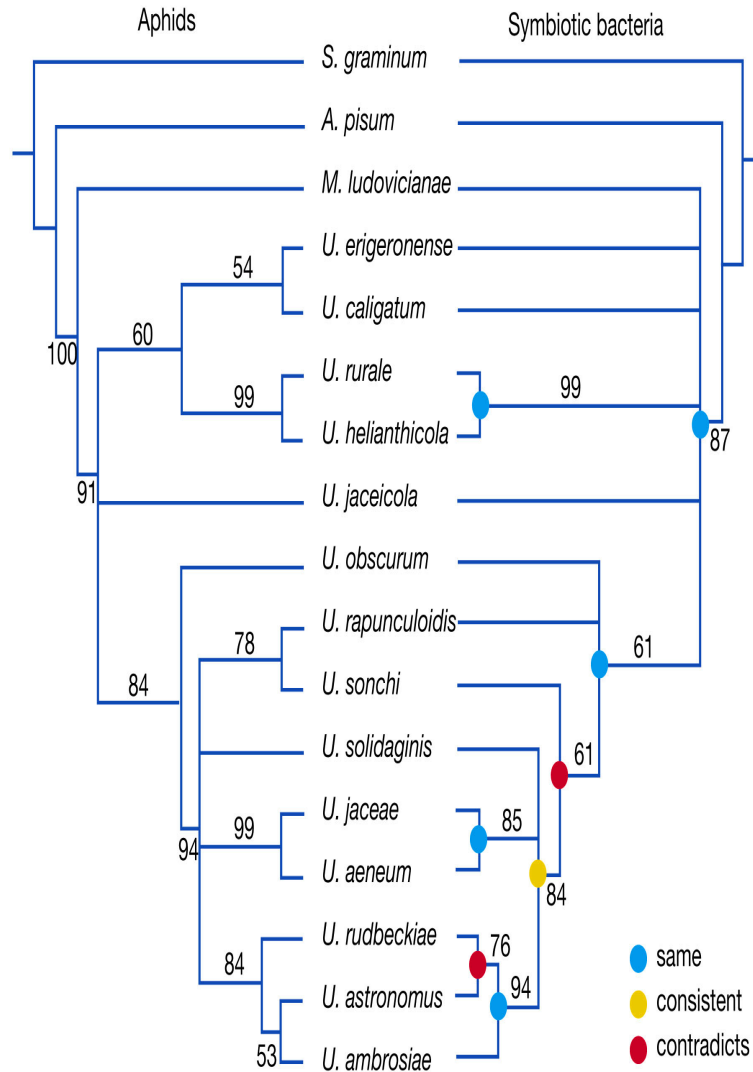

Copyright © 2004 Pearson Prentice Hall, Inc.

Clark et al. (2000)

Coevolution

Aphids and bacteria are symbiotic

Given this close relationship, we might expect that speciation in an aphid would cause parallel speciation in the bacteria

When comparing phylogenies for each group we see evidence for **reciprocal cladogenesis** (but also contradictions)

Testing evolutionary hypotheses

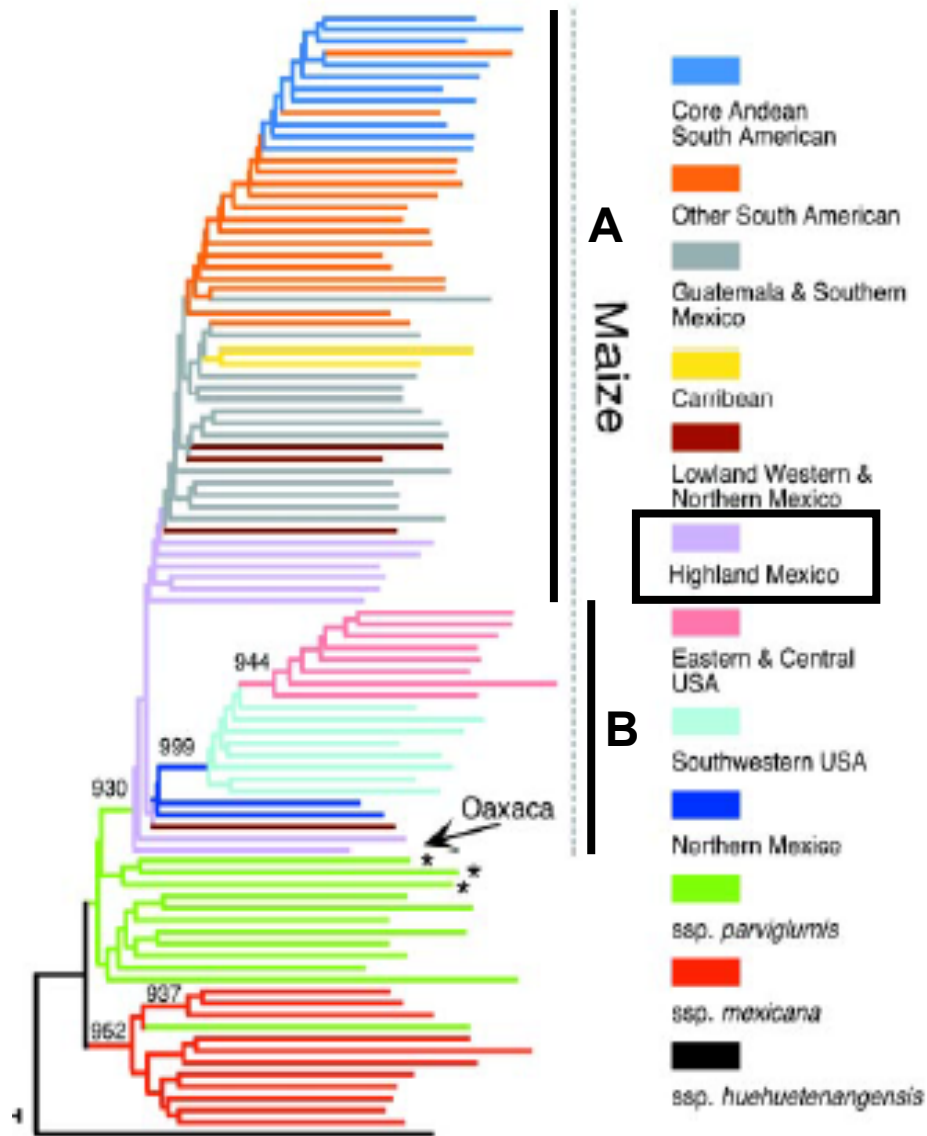

Geographic origins

Where did domestic corn (*Zea mays* maize) originate?

Populations from **Highland Mexico** are at the base of each maize clade

Matsuoka et al. (2002)

Testing evolutionary hypotheses

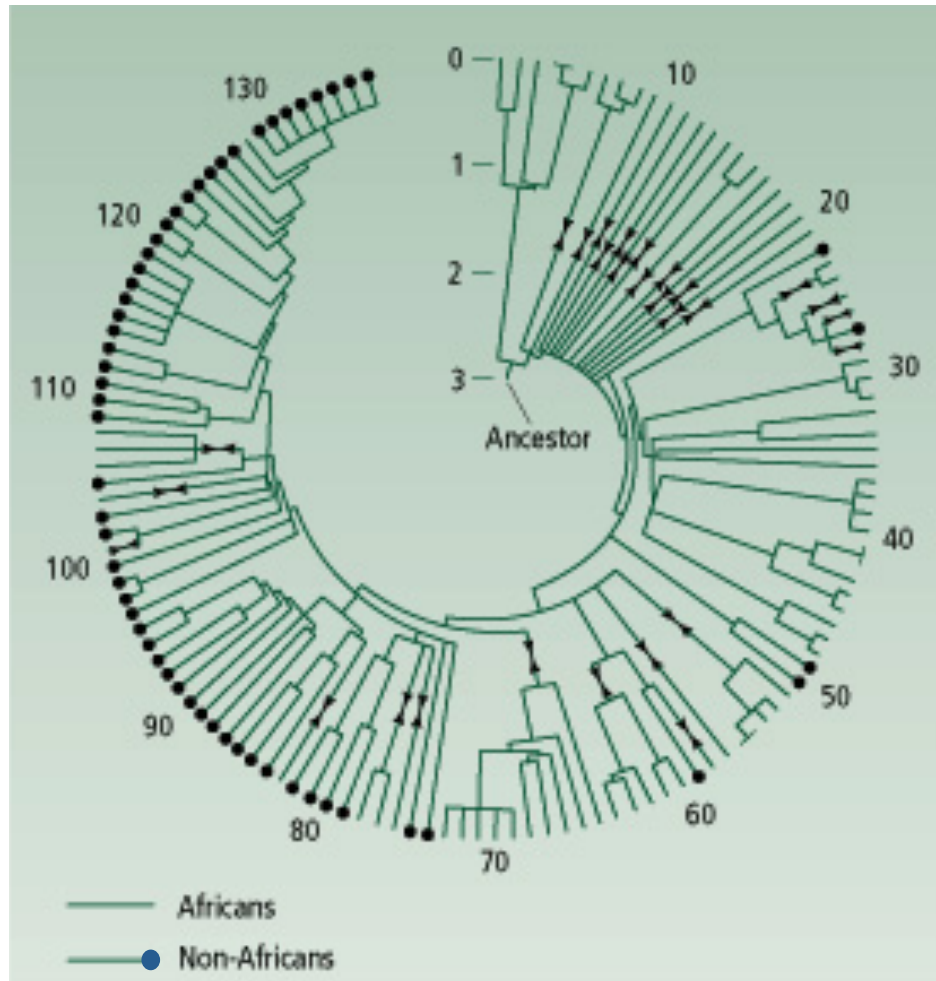

Geographic origins

Where did humans originate?

Each tip is one of 135 different mitochondrial DNA types found among 189 individual humans

African mtDNA types are clearly basal on the tree, with the non-African types derived

Suggests that humans originated in Africa

Vigilant et al. (1991) *Science*

Molecular phylogenetics

Study of evolutionary relationships between genes and species

- The actual pattern of evolutionary history is the **phylogeny** or **evolutionary/phylogenetic tree** which we try to estimate.

- **A tree is a mathematical structure which is used to model the actual evolutionary history of a group of sequences or organisms.**

Rooted and Unrooted Trees

- Most phylogenetic methods produce unrooted trees. This is because they detect differences between sequences, but have no means to orient residue changes relatively to time.
- Two means to root an unrooted tree :
 - The outgroup method : include in the analysis a group of sequences known *a priori* to be external to the group under study; the root is by necessity on the branch joining the outgroup to other sequences.
 - Make the molecular clock hypothesis : all lineages are supposed to have evolved with the same speed since divergence from their common ancestor. The root is at the equidistant point from all tree leaves.

Unrooted Tree

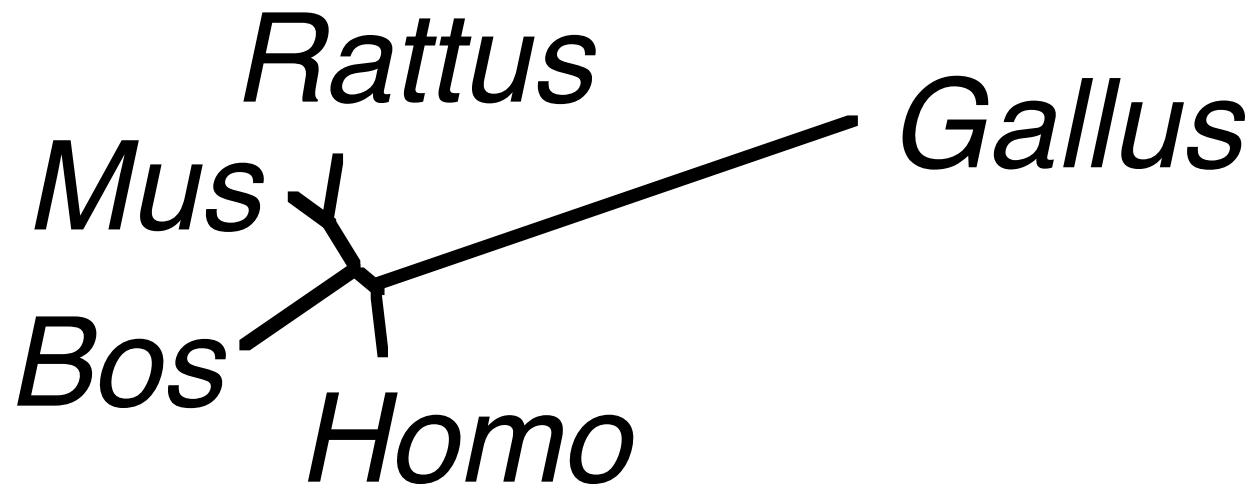

0.02
|

Rooted Tree

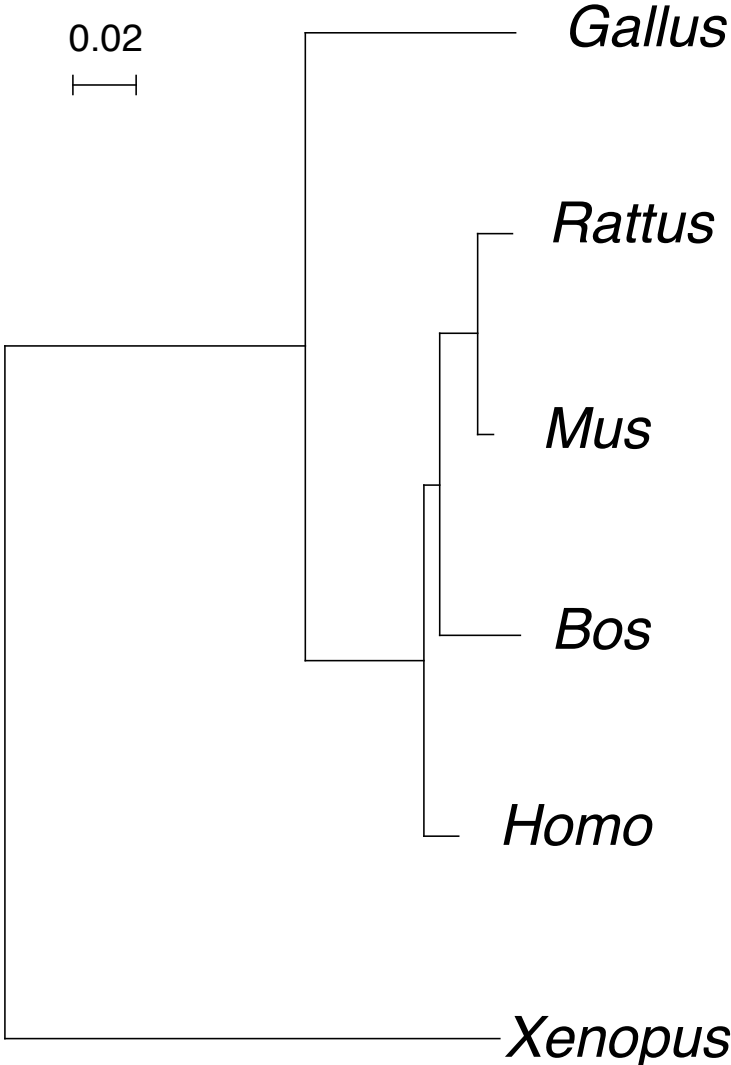

Cladograms, ultrametric and additive trees

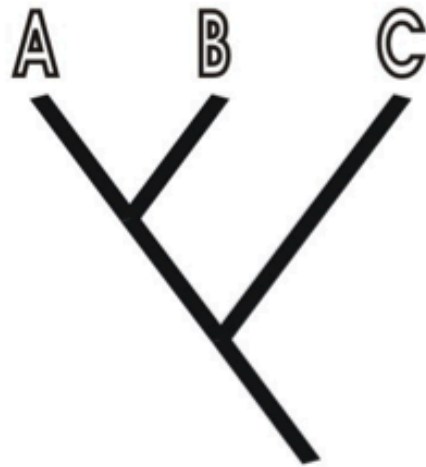

Cladogram

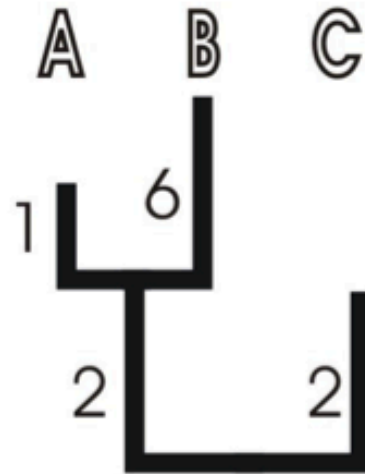

Additive tree

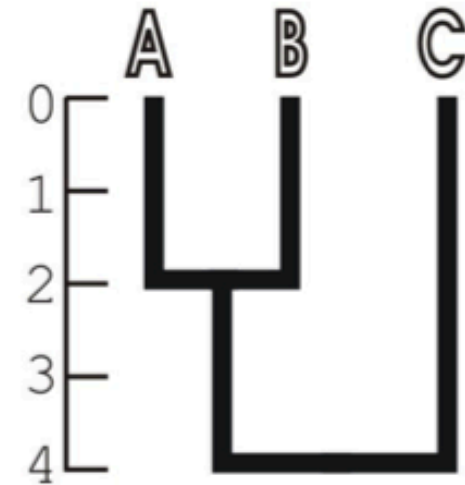

Ultrametric tree

- a) **CLADOGRAM**: tree shows the relative recency of common ancestry; Do not tell us anything about the evolutionary distances between taxa.
- b) **ADDITIVE TREES**: Branch lengths in these trees are related to attributes such as number of nucleotide change per site.
- c) **ULTRAMETRIC TREES**: have terminal nodes that are the same distance from the root

Types of phylogenetic analysis methods

- Phenetic: trees are constructed based on observed characteristics, not on evolutionary history
 - Cladistic: trees are constructed based on fitting observed characteristics to some model of evolutionary history
- Distance methods
- Parsimony and Maximum Likelihood methods

Phenetics and Cladistics

Phenetics (Michener and Sokal, 1957): Pheneticists argued that classifications should encompass as many variable characters as possible, these characters being analysed by rigorous mathematical methods.

Such methods (exp. distance based) place a greater emphasis on the relationships among data sets than the paths they have taken to arrive at their current states.

Cladistics (Hennig 1966): emphasizes the need for large datasets but differs from phenetics in that it does not give equal weight to all characters.

Cladists, are generally more interested in evolutionary pathways than in relationships (exp. maximum parsimony).

Phenetics

- Study of phylogenetics based on **shared** traits
- Problem: not all shared traits are informative about evolutionary relationships

Cladistics

- Study of phylogenetic relationships based on shared **derived** traits

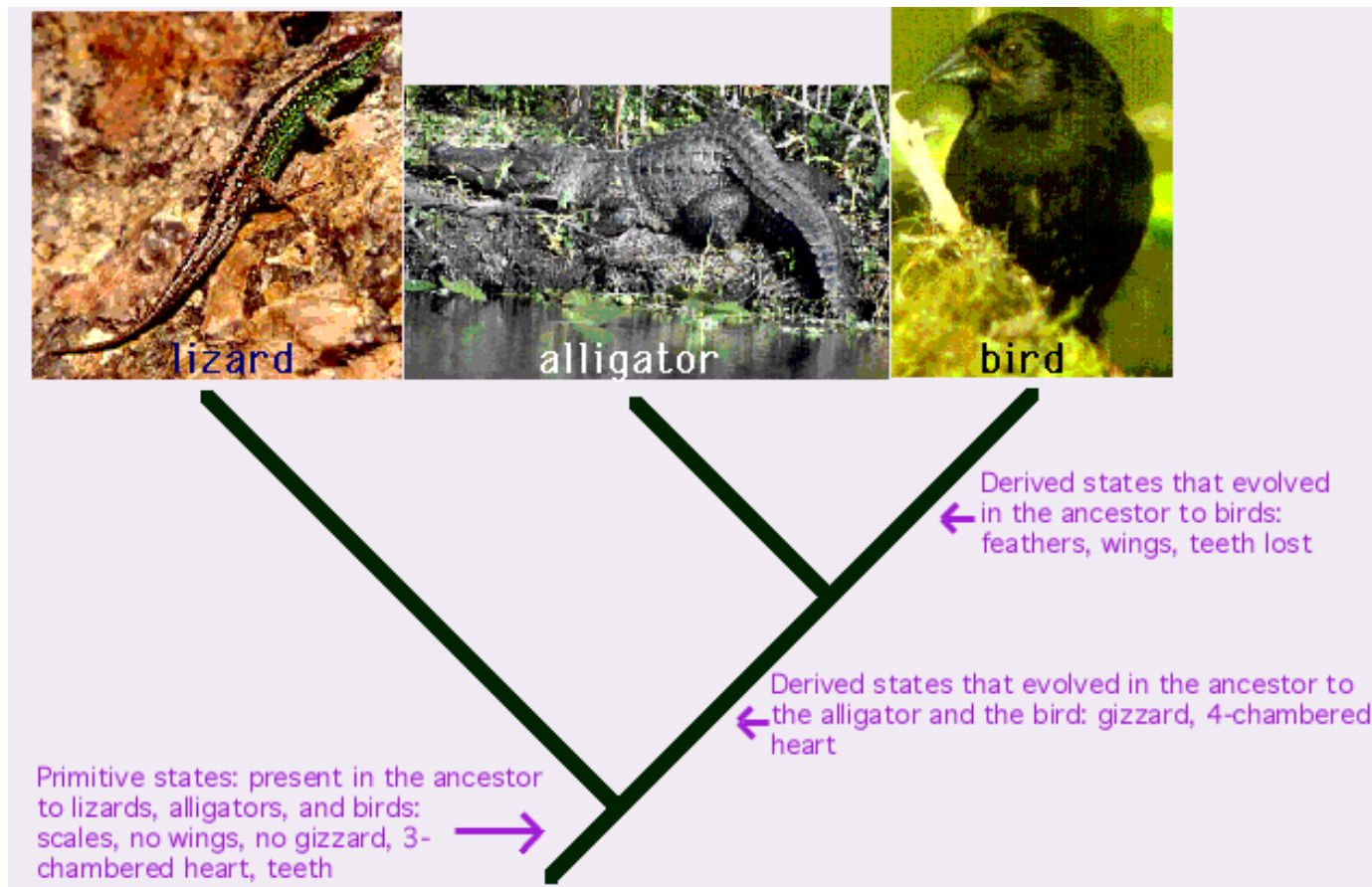

Caveat: homoplasy - independent evolution of the same character

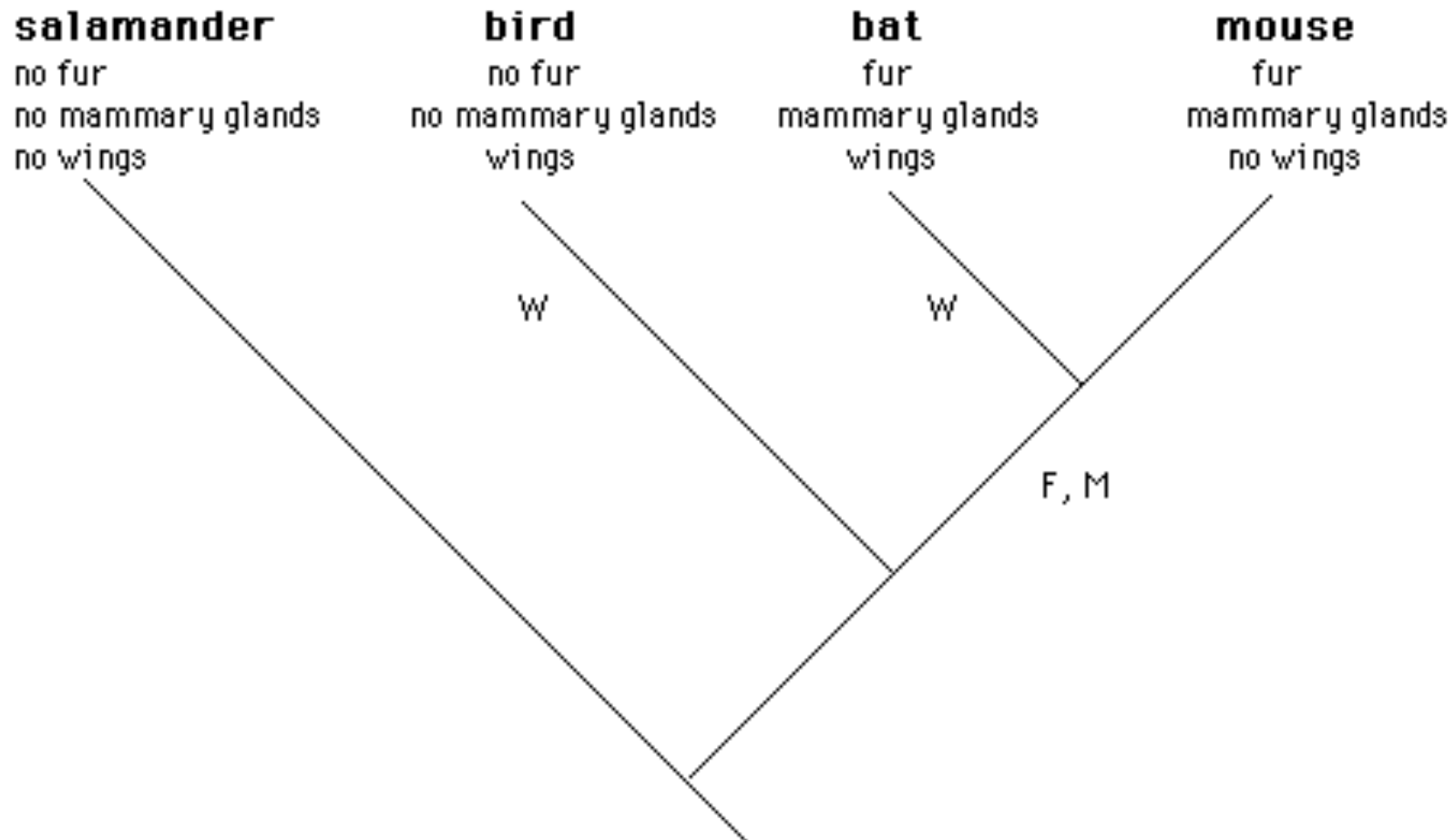

Sequences Reflect Relationships

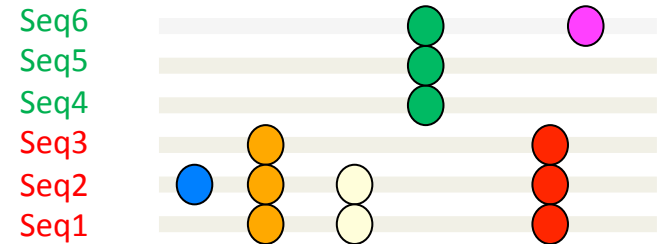
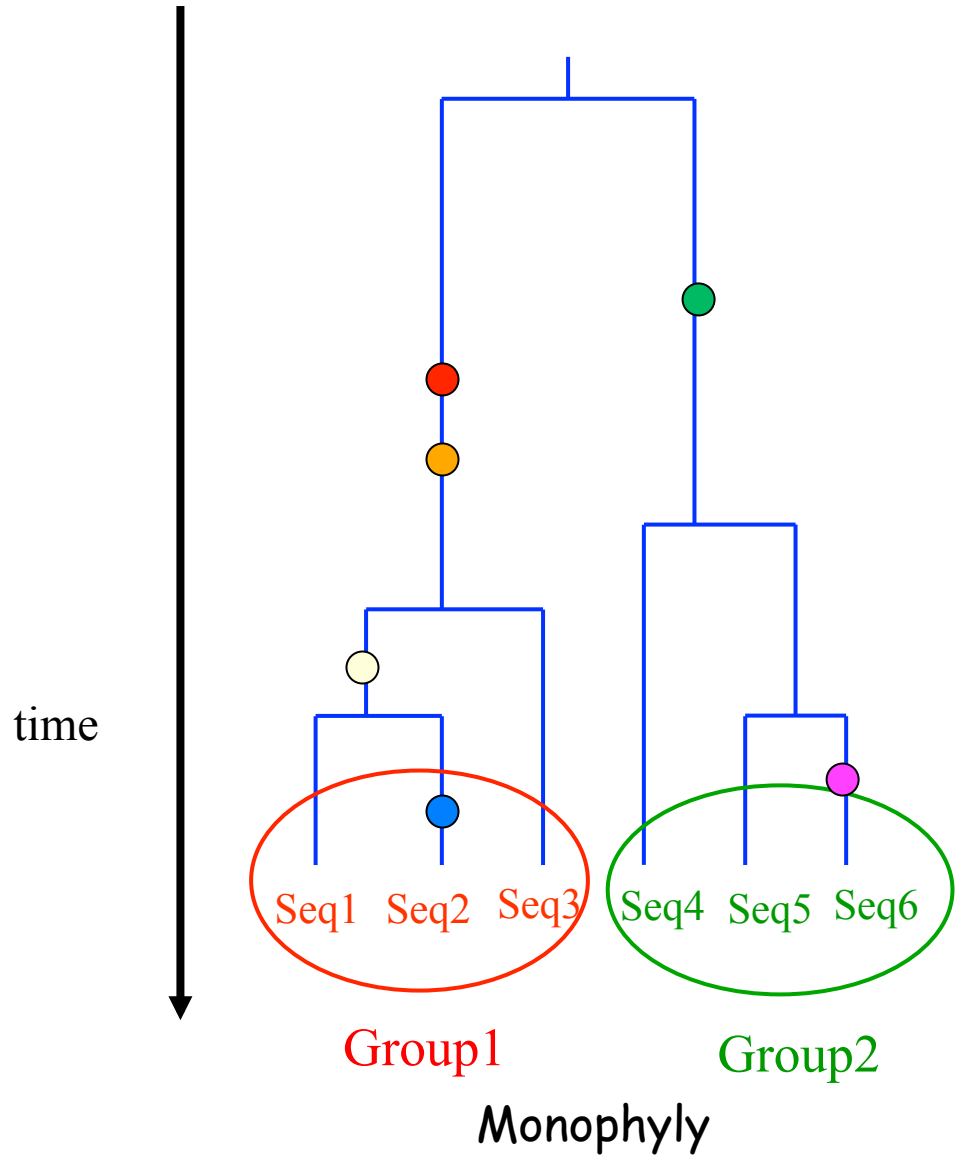

● ● ... =derived mutations

What Sequences to Study?

- Study more than just one region!
- Different sequences evolve at different rates
 - Proteins
 - Highly variable sequences (ex: immunoglobulin genes)
 - Highly conserved (actin, rRNA coding regions)
 - Different regions within a single gene can evolve at different rates (conserved vs. variable domains)

Molecular Phylogenies

- The gene compared must evolve at a rate comparable to the divergence time of the organism; for example:
 - 18S rRNA gene for phylum-level divergences since it evolves very slowly.
 - Hemoglobin genes for mammalian orders.
 - Mitochondrial DNA for species divergences within a genus.
 - Repetitive DNA sequences (e.g. microsatellites) for individuals within species.

DNA is a good tool for taxonomy

DNA sequences have advantages over taxonomic characters:

- Unambiguous
- Large numbers of characters can be scored for each individual

DNA is a good tool for taxonomy

| | | | | | | | | | | |
|----------|-----|-------------|-------------|-------------|--------------|-------------|-----|---------------------|-------------|---------------------|
| A | aat | tc g | ctt | cta | gga | atc | tgc | cta | atc | ctg |
| B | ... | ..a | .. g | ..a | . t . | ... | ... | t .. | ... | .. a |
| C | ... | ..a | .. c | .. c | ... | .. t | ... | ... | ... | t . a |
| D | ... | ..a | .. a | .. g | .. g | .. t | ... | t . t | .. t | t .. |

Each nucleotide difference is a character

Molecular Phylogeny

- Starting point: a set of homologous, aligned DNA or protein sequences
- Result of the process: a tree describing evolutionary relationships between studied sequences
 - = a genealogy of sequences
 - = a phylogenetic tree

CLUSTAL W (1.74) multiple sequence alignment

```
Xenopus      ATGCATGGGCCAACATGACCAGGAGTTGGTGTCTCGGTCCAAACAGCGTT---GGCTCTCTA
Gallus       ATGCATGGGCCAGCATGACCAGCAGGAGGTAGC---CAAATAACACCAACATGCAAATG
Bos          ATGCATCCGCCACCATGACCAGCAGGAGGTAGCACCCAAAACAGCACCAACGTGCAAATG
Homo         ATGCATCCGCCACCATGACCAGCAGGAGGTAGCACTCAAACAGCACCAACGTGCAAATG
Mus          ATGCATCCGCCACCATGACCAGCAGGAGGTAGCACTCAAACAGCACCAACGTGCAAATG
Rattus       ATGCATCCGCCACCATGACCAGCGGGAGGTAGCTCTCAAACAGCACCAACGTGCAAATG
*****      ***** ***** *   *** *   *   *** * *

```



Alignment and Gaps

- The quality of the alignment is essential : each column of the alignment (site) is supposed to contain homologous residues (nucleotides, amino acids) that derive from a common ancestor.
 - ==> Unreliable parts of the alignment must be omitted from further phylogenetic analysis.
- Most methods take into account only substitutions ; gaps (insertion/deletion events) are not used.
 - ==> gaps-containing sites are ignored.

| | |
|---------|--|
| Xenopus | ATGCATGGGCCAACATGACCAGGAGTTGGTGTCggtCCAAACAGCGTT---GGCTCTCTA |
| Gallus | ATGCATGGGCCAGCATGACCAGCAGGAGGTAGC---CAAATAACACCaacATGCAAATG |
| Bos | ATGCATCCGCCACCATGACCAGCAGGAGGTAGCagtCAAACAGCACCaacGTGCAAATG |
| Homo | ATGCATCCGCCACCATGACCAGCAGGAGGTAGCagtCAAACAGCACCaacGTGCAAATG |
| Mus | ATGCATCCGCCACCATGACCAGCAGGAGGTAGCactCAAACAGCACCaacGTGCAAATG |
| Rattus | ATGCATCCGCCACCATGACCAGCGGGAGGTAGCtctCAAACAGCACCaacGTGCAAATG |

Caveat: homoplasy: independent evolution of the same character

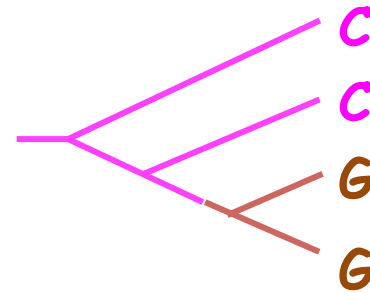
Evolutionary relationship:
Shared ancestral characters
Shared derived characters



Homoplasy (independent evolution of the same character):

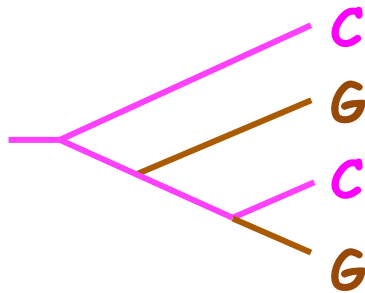

Caveat: Saturation i.e. loss of phylogenetic signal

- When compared homologous sequences have experienced too many residue substitutions since divergence, it is impossible to determine the phylogenetic tree, whatever the tree-building method used.

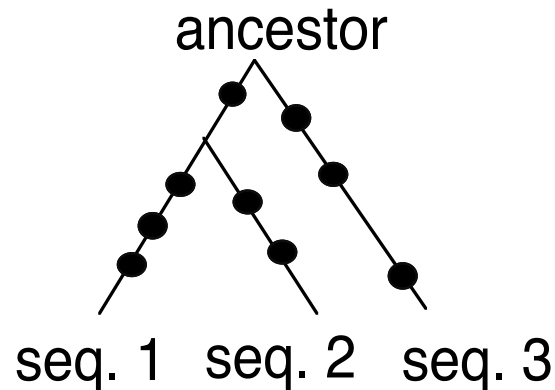

- NB: often saturation may not be detectable

Caveats: horizontal gene transfer

- Common in prokaryotes (bacteria) and viruses: an organism incorporates genetic material from another organism
- Exists in Eukaryotes: mitochondrial DNA or chloroplast DNA transferred to the nucleus

Homolog - Paralog - Ortholog

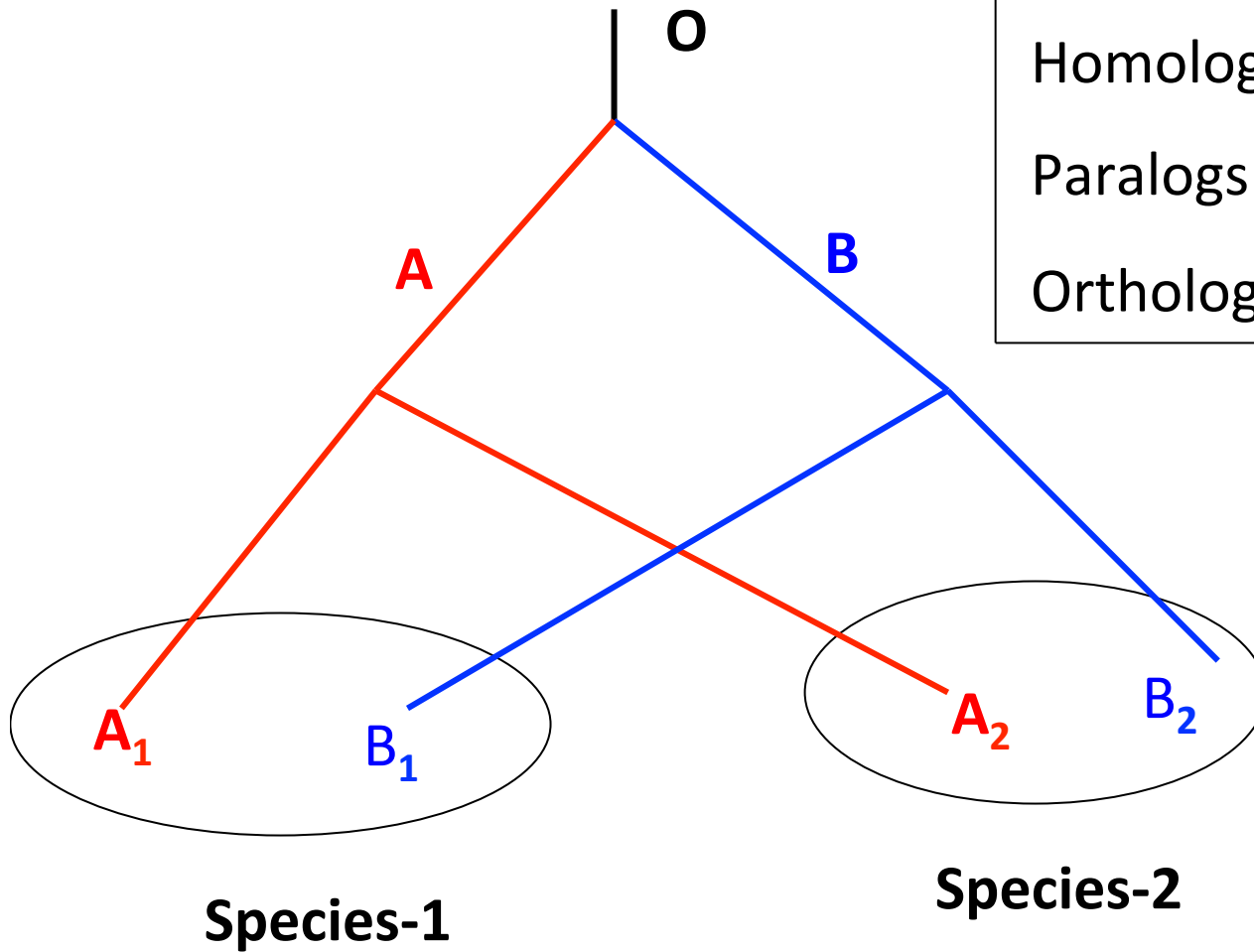

Homologs: A_1, B_1, A_2, B_2

Paralogs: A_1 vs B_1 and A_2 vs B_2

Orthologs: A_1 vs A_2 and B_1 vs B_2

Sequence analysis

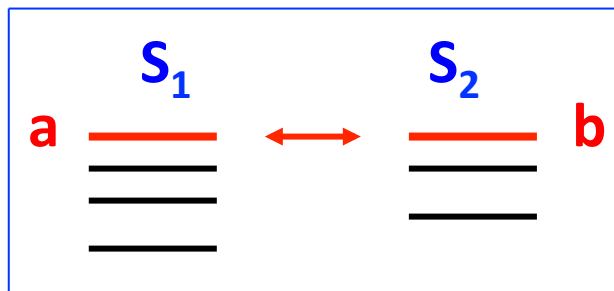

Caveats: Orthologs vs. Paralogs

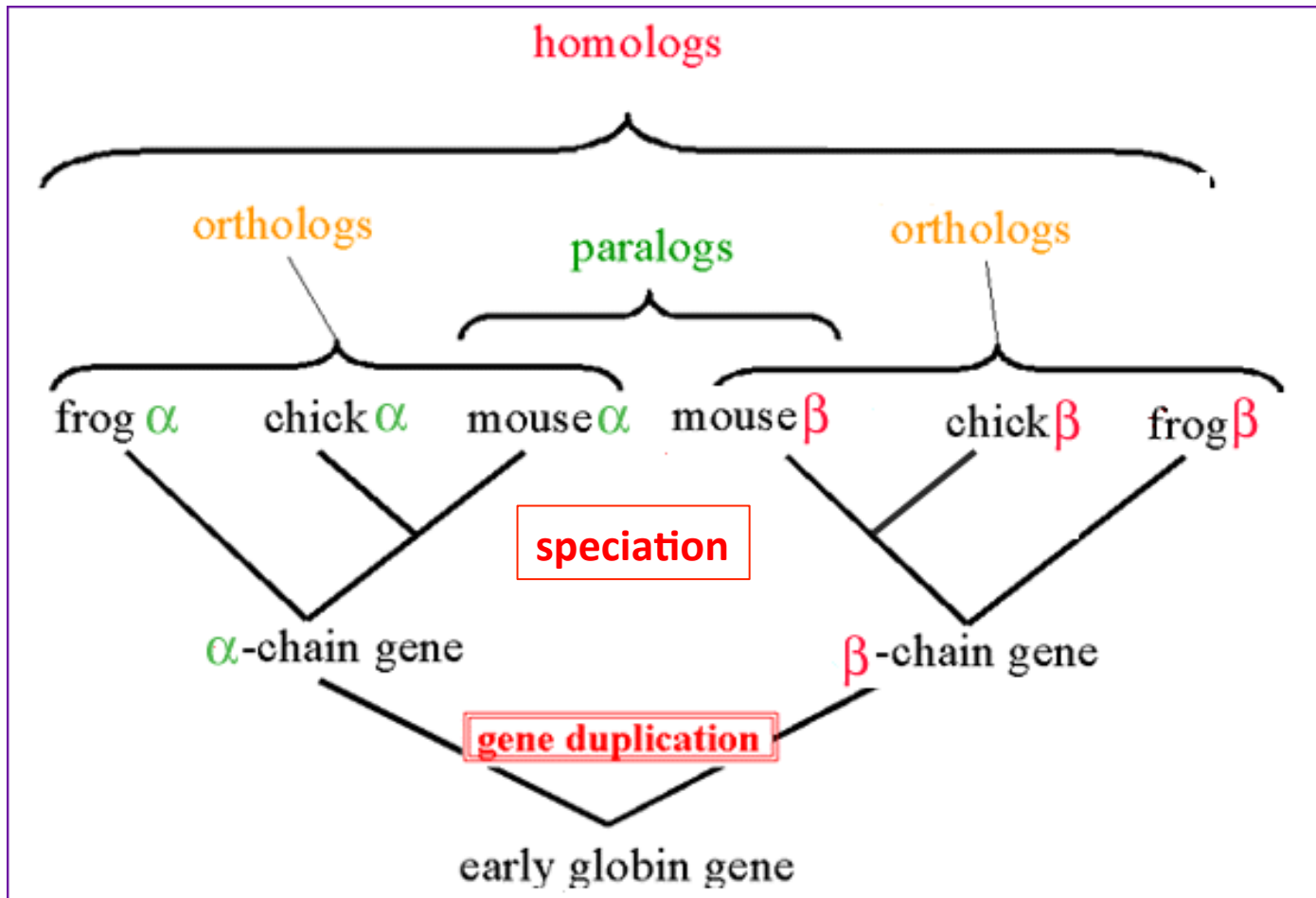

Tree Building Goals

- Maximize shared derived character states in a lineage
- Minimize homoplasies
 - Parallel changes, convergences, and reversals of character states between and within lineages

Tree building methods

- Distance methods
- Maximum Parsimony
- Maximum likelihood
- Bayesian inference

All methods can be used with different substitution models

Distance methods

- Starts from a multiple sequence alignment
- Makes a matrices of pairwise sequence distances (number of differences)
- Builds a phylogenetic tree

Correspondence between trees and distance matrices

- Any phylogenetic tree induces a matrix of distances between sequence pairs
- “Perfect” distance matrices correspond to a single phylogenetic tree

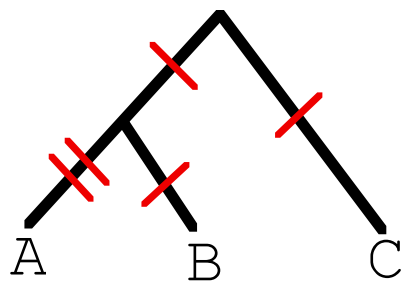

tree



| | A | B | C |
|---|----------|----------|----------|
| A | 0 | | |
| B | 3 | 0 | |
| C | 4 | 3 | 0 |

distance matrix

Building phylogenetic trees by distance methods

General principle :

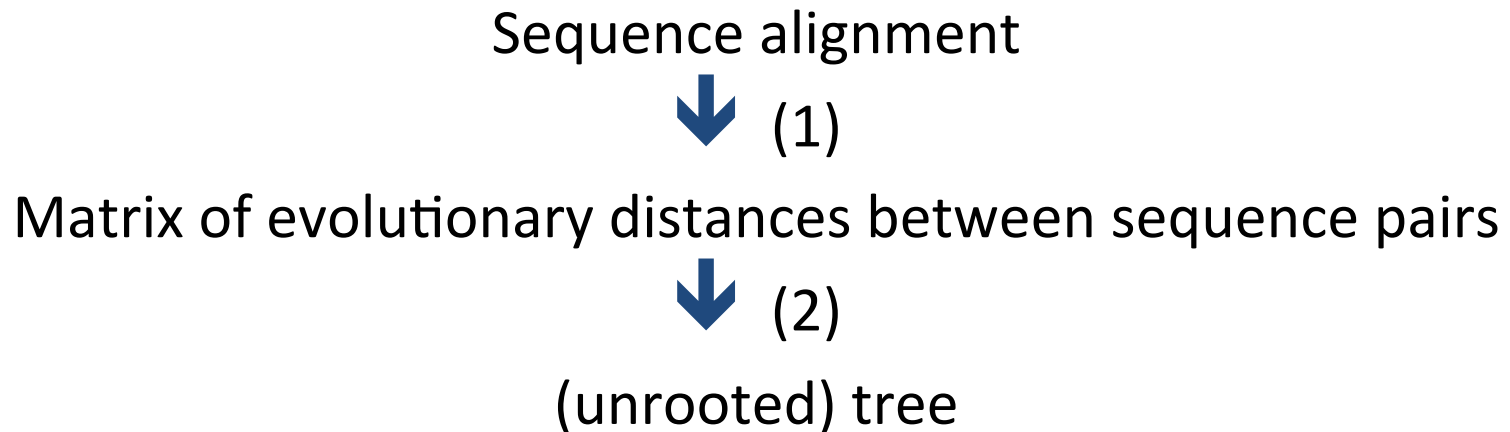

- (1) Measuring evolutionary distances.
- (2) Tree computation from a matrix of distance values.

Multiple sequence alignment

Species A **ATGGCTATTCTTATAGTACG**

Species B **ATCTAGTCTTATATTACA**

Aligned sequences

Species A **ATGGCTATTCTTATAGTACG**

Species B **ATC--TAGTCTTATATTACA**

Multiple sequence alignment

- Different softwares: ClustalW, ClustalX, Muscle

Minimize total score

Species A **A**TGGCT**A**TTCTT**A**TAGT**A**CG
Species B **A**TC --TAGTCTT**A**TATT**A**CA

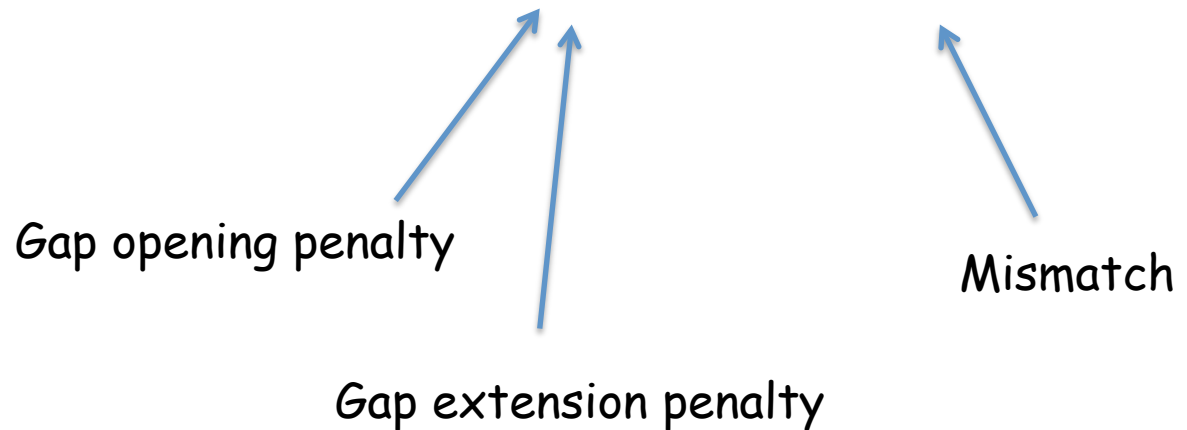

Principle of distance methods

| Taxa | Characters |
|-----------|----------------------|
| Species A | ATGGCTATTCTTATAGTACG |
| Species B | ATCGCTAGTCTTATATTACA |
| Species C | TTCACTAGACCTGTGGTCCA |
| Species D | TTGACCAGACCTGTGGTCCG |
| Species E | TTGACCAGTTCTCTAGTTCG |

Transform the sequence data into pairwise distances

| | A | B | C | D | E |
|-----------|------|------|------|------|------|
| Species A | ---- | 0.20 | 0.50 | 0.45 | 0.40 |
| Species B | ---- | ---- | 0.40 | 0.55 | 0.50 |
| Species C | ---- | ---- | ---- | 0.15 | 0.40 |
| Species D | ---- | ---- | ---- | ---- | 0.25 |
| Species E | ---- | ---- | ---- | ---- | ---- |

Evolutionary Distances

- They measure the total number of substitutions that occurred on both lineages since divergence from last common ancestor.
- Divided by sequence length.
- Expressed in substitutions / site

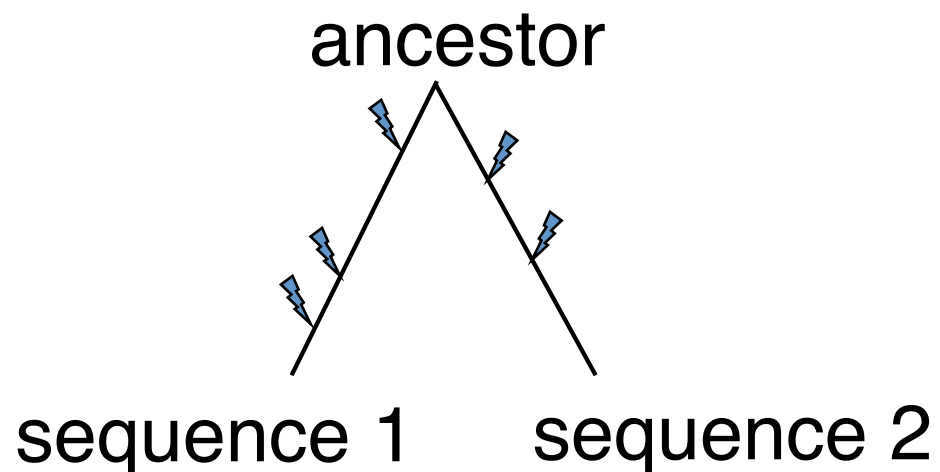

Quantification of evolutionary distances (1):

The problem of hidden or multiple changes

- D (true evolutionary distance) \geq fraction of observed differences (p)

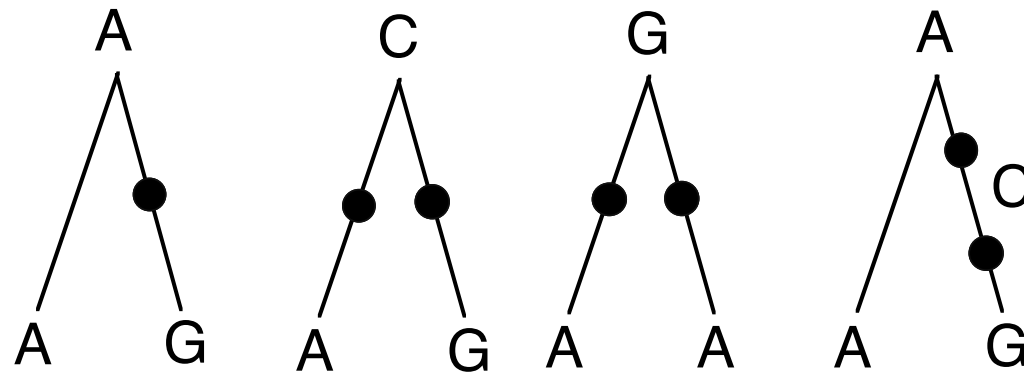

- $D = p + \text{hidden changes}$
- Through hypotheses about the nature of the residue substitution process, it becomes possible to estimate D from observed differences between sequences.

Substitution models

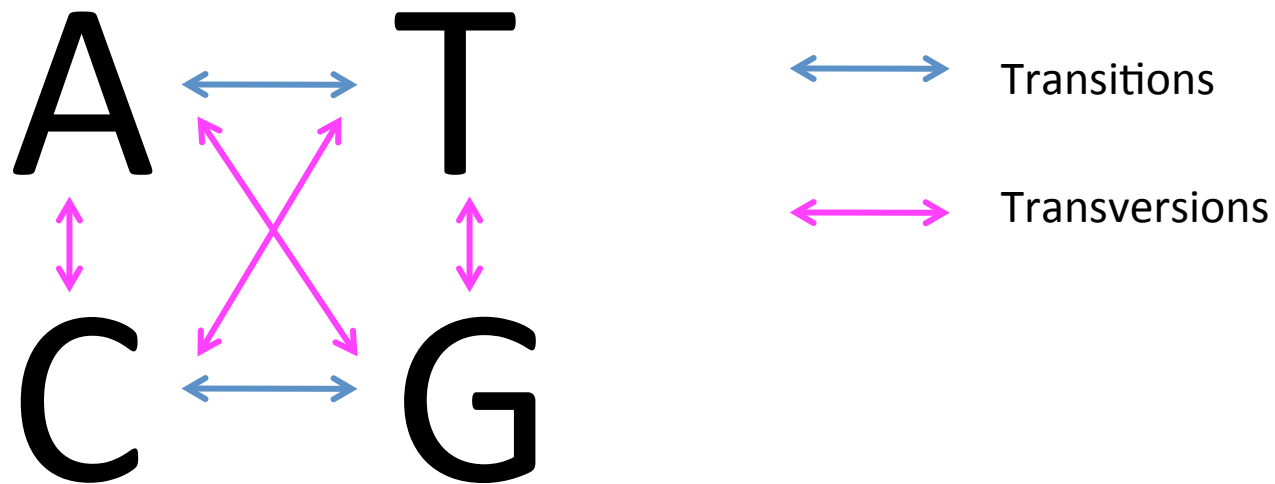

Variation in rates

Quantification of evolutionary distances (2): Kimura's two parameter distance (DNA)

- Hypotheses of the model :
 - (a) All sites evolve independently and following the same process.
 - (b) Substitutions occur according to two probabilities :
One for transitions, one for transversions.
Transitions : G \leftrightarrow A or C \leftrightarrow T Transversions : other changes
 - (c) The base substitution process is constant in time.
- Quantification of evolutionary distance (d) as a function of the fraction of observed differences (p : transitions, q : transversions):

$$d = -\frac{1}{2} \ln[(1 - 2p - q)\sqrt{1 - 2q}]$$

Kimura (1980) J. Mol. Evol. 16:111

Quantification of evolutionary distances (3): PAM and Kimura's distances (proteins)

- Hypotheses of the model (Dayhoff, 1979) :
 - (a) All sites evolve independently and following the same process.
 - (b) Each type of amino acid replacement has a given, empirical probability :

Large numbers of highly similar protein sequences have been collected; probabilities of replacement of any a.a. by any other have been tabulated.
 - (c) The amino acid substitution process is constant in time.
- Quantification of evolutionary distance (d) :

the number of replacements most compatible with the observed pattern of amino acid changes and individual replacement probabilities.
- Kimura's empirical approximation : $d = -\ln(1 - p - 0.2 p^2)$
(Kimura, 1983) where p = fraction of observed differences

Quantification of evolutionary distances (4): Other distance measures

- Several other, more realistic models of the evolutionary process at the molecular level have been used :
 - Accounting for biased base compositions (Tajima & Nei).
 - Accounting for variation of the evolutionary rate across sequence sites.
 - etc ...

Quantification of evolutionary distances (5): Synonymous and non-synonymous distances (coding DNA): K_a , K_s

- Hypothesis of previous models :
 - (a) All sites evolve independently and following the same process.
- Problem: in protein-coding genes, there are two classes of sites with very different evolutionary rates.
 - non-synonymous substitutions (change the a.a.): slow
 - synonymous substitutions (do not change the a.a.): fast
- Solution: compute two evolutionary distances
 - K_a = non-synonymous distance
= $\text{nbr. non-synonymous substitutions} / \text{nbr. non-synonymous sites}$
 - K_s = synonymous distance
= $\text{nbr. synonymous substitutions} / \text{nbr. synonymous sites}$

Distance methods

- **UPGMA** (Unweighted Pair Group Method with Arithmetic mean): same rate of evolution on each branch
- The **Neighbor Joining** method = most popular method

does not assume the same rate of evolution on each branch of a tree

Resampling procedures: The Bootstrap

- Randomly resample the data X-times and infer a phylogeny
- Derive the frequency with which a particular node in the original tree appears in all of the resampled trees

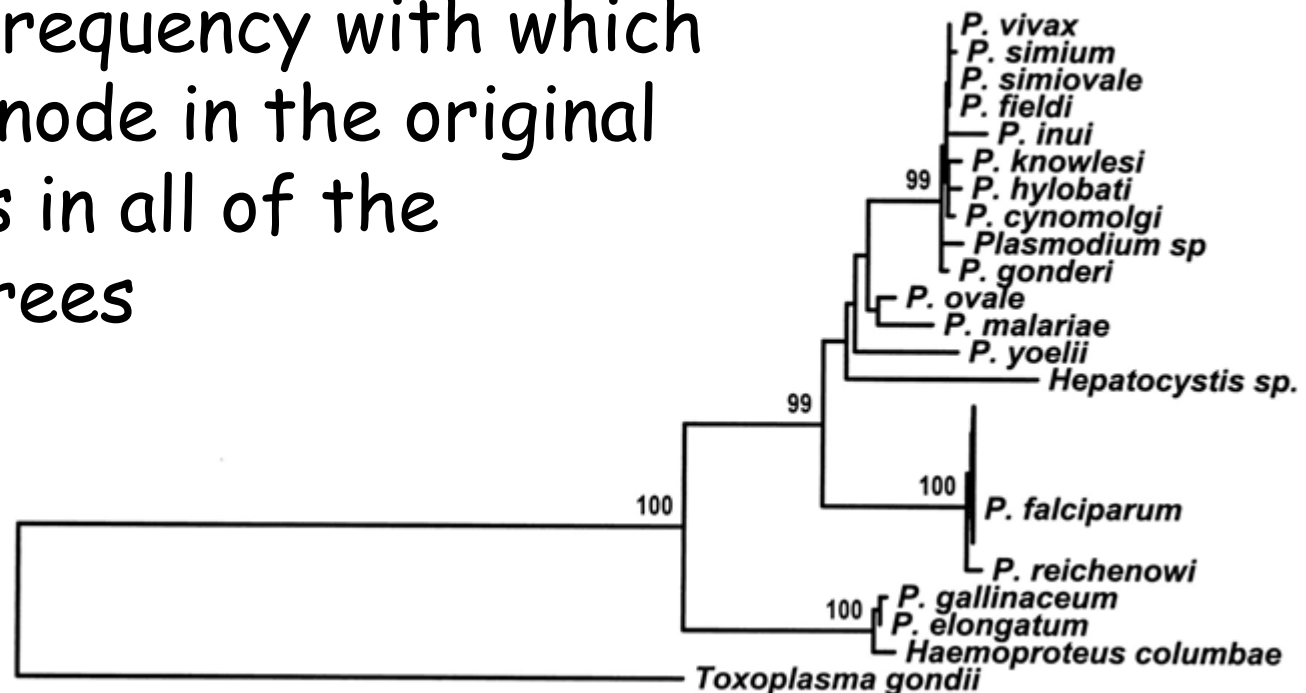

Bootstrap procedure

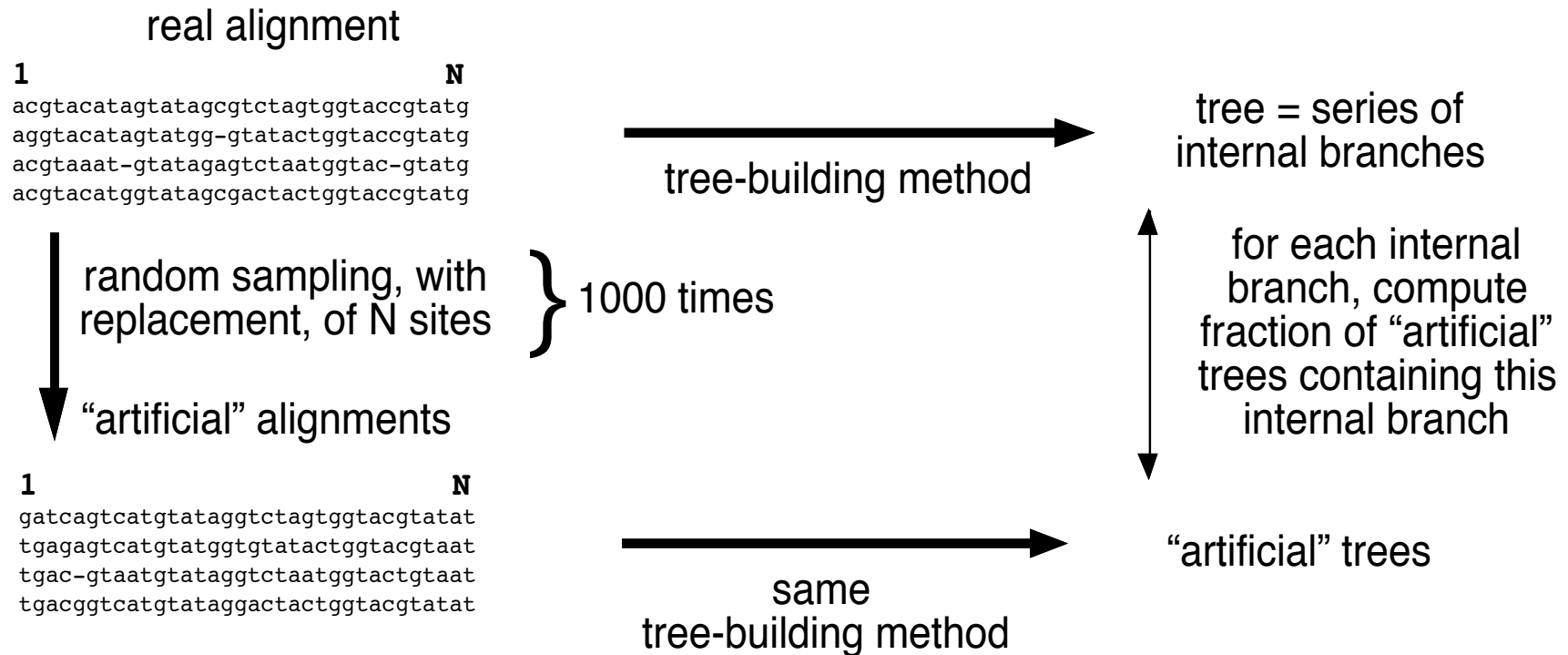

The support of each internal branch is expressed as percent of replicates.

"bootstrapped" tree

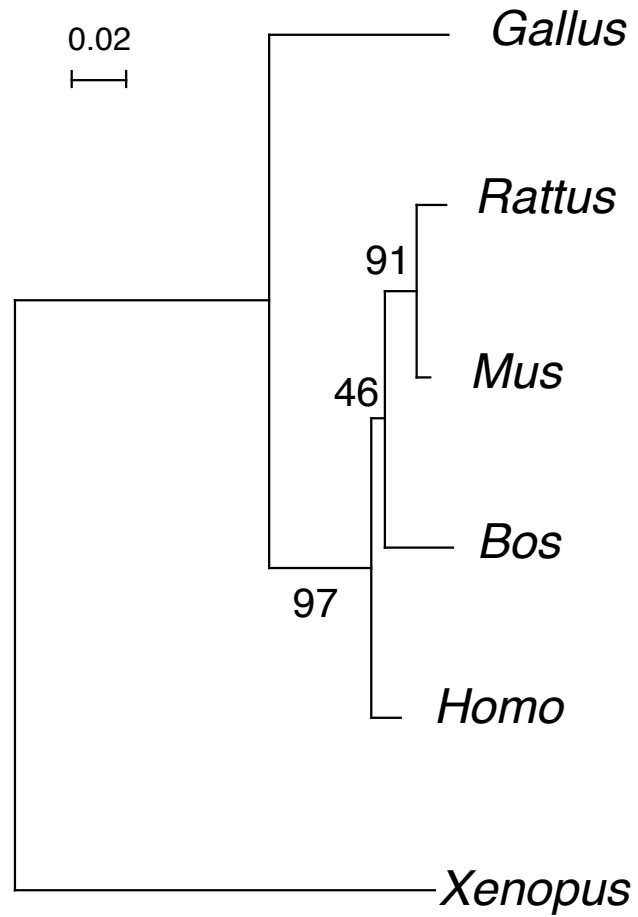

Bootstrap procedure : properties

- Internal branches supported by $\geq 90\%$ of replicates are considered as statistically significant.
- The bootstrap procedure only detects if sequence length is enough to support a particular node.
- The bootstrap procedure does not help determining if the tree-building method is good. A wrong tree can have 100 % bootstrap support for all its branches!

Building Trees with Parsimony

- **Parsimony** involves evaluating all possible trees and giving each a score based on the number of evolutionary changes that are needed to explain the observed data.
- The best tree is the one that requires the fewest base changes for all sequences to derive from a common ancestor.

Maximum likelihood and bayesian methods

- Allows for substitution rates to differ on lineages and sites: appropriate for distantly related species
- Estimates the likelihood of a tree = probability of the data given an evolutionary model
- Complex and computationally intensive!

Gene tree vs. Species tree

- The evolutionary history of genes reflects that of species that carry them, except if :
 - horizontal transfer = gene transfer between species (*e.g.* bacteria, mitochondria)
 - Gene duplication : orthology/ paralogy

Recap: Orthology / Paralogy

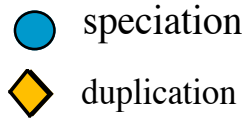

Homology : two genes are homologous iff they have a common ancestor.

↔ *Orthology* : two genes are orthologous iff they diverged following a speciation event.

↔ *Paralogy* : two genes are paralogous iff they diverged following a duplication event.

⚠ Orthology \neq functional equivalence

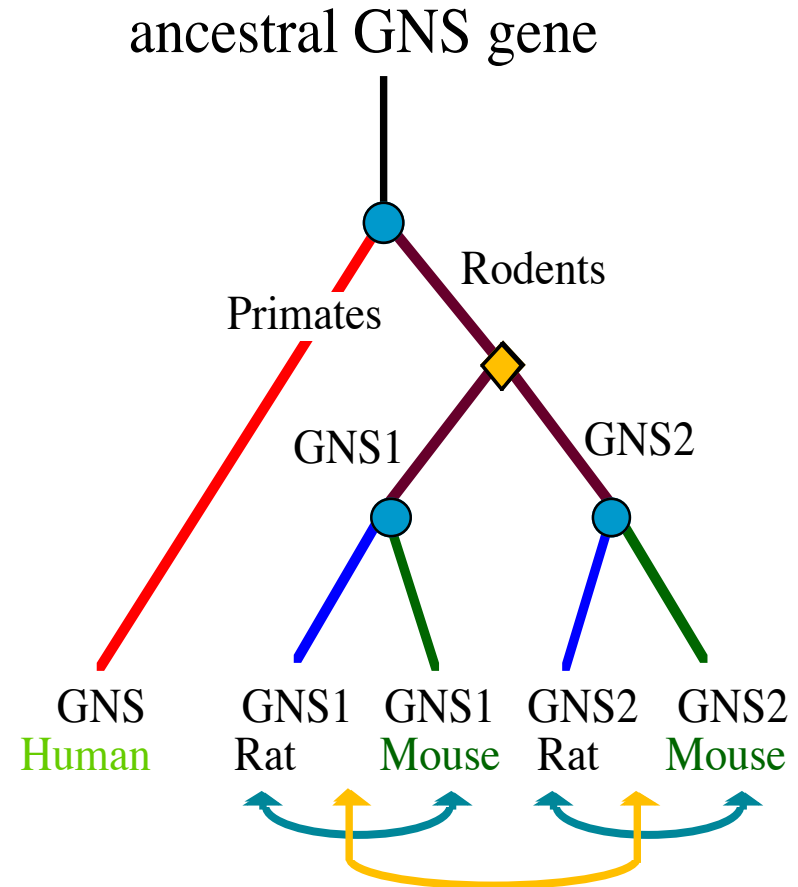

Reconstruction of species phylogeny: artefacts due to paralogy

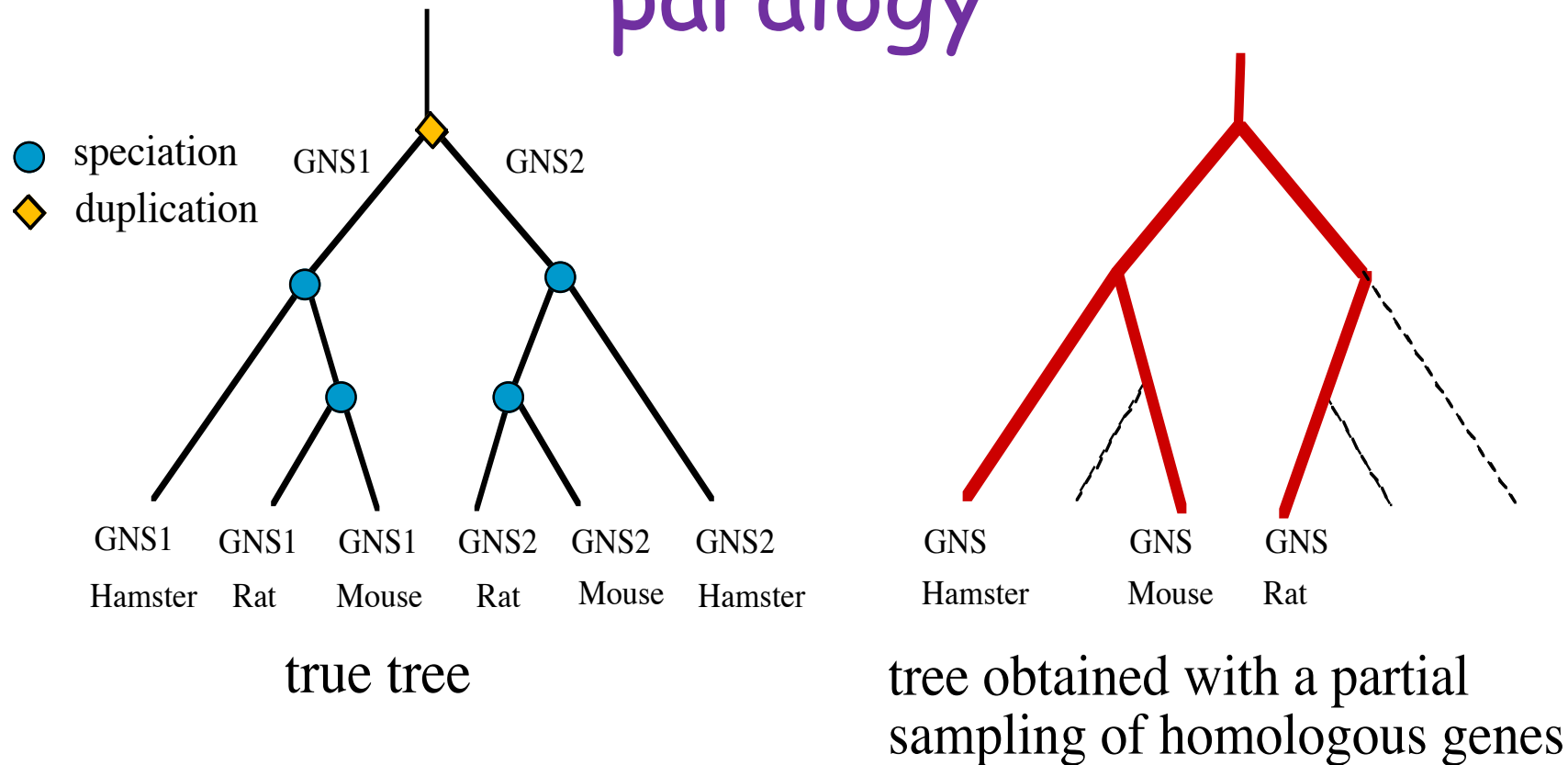

!! Gene loss can occur during evolution : even with complete genome sequences it may be difficult to detect paralogy !!

WWW resources for molecular phylogeny (1)

■ Compilations

⇒ A list of sites and resources:

<http://www.ucmp.berkeley.edu/subway/phylogen.html>

⇒ An extensive list of phylogeny programs

<http://evolution.genetics.washington.edu/phylip/software.html>

• Databases of rRNA sequences and associated software

⇒ The rRNA WWW Server - Antwerp, Belgium.

<http://rrna.uia.ac.be>

⇒ The Ribosomal Database Project - Michigan State University

<http://rdp.cme.msu.edu/html/>

WWW resources for molecular phylogeny (2)

■ Database similarity searches (Blast) :

<http://www.ncbi.nlm.nih.gov/BLAST/>

<http://www.infobiogen.fr/services/menuserv.html>

<http://bioweb.pasteur.fr/seqanal/blast/intro-fr.html>

<http://pbil.univ-lyon1.fr/BLAST/blast.html>

■ Multiple sequence alignment

⇒ ClustalX : multiple sequence alignment with a graphical interface (for all types of computers).

<http://www.ebi.ac.uk/FTP/index.html> and go to 'software'

⇒ Web interface to ClustalW algorithm for proteins:

<http://pbil.univ-lyon1.fr/> and press "**clustal**"

WWW resources for molecular phylogeny (3)

- **Sequence alignment editor**

- ⇒ SEAVIEW : for windows and unix

- <http://pbil.univ-lyon1.fr/software/seaview.html>

- **Programs for molecular phylogeny**

- ⇒ PHYLIP : an extensive package of programs for all platforms

- <http://evolution.genetics.washington.edu/phylip.html>

- ⇒ CLUSTALX : beyond alignment, it also performs NJ

- ⇒ PAUP* : a very performing commercial package

- <http://paup.csit.fsu.edu/index.html>

- ⇒ PHYLO_WIN : a graphical interface, for unix only

- <http://pbil.univ-lyon1.fr/software/phylowin.html>

- ⇒ MrBayes : Bayesian phylogenetic analysis <http://>

- morphbank.ebc.uu.se/mrbayes/

- ⇒ PHYML : fast maximum likelihood tree building [http://www.lirmm.fr/](http://www.lirmm.fr/~guindon/phyml.html)

- [~guindon/phyml.html](http://www.lirmm.fr/~guindon/phyml.html)

- ⇒ WWW-interface at Institut Pasteur, Paris

- <http://bioweb.pasteur.fr/seqanal/phylogeny>

WWW resources for molecular phylogeny (4)

- **Tree drawing**

NJPLOT (for all platforms)

<http://pbil.univ-lyon1.fr/software/njplot.html>

- **Lecture notes of molecular systematics**

<http://www.bioinf.org/molsys/lectures.html>

END

Thank you!